

USER MANUAL

LT3BC Series

LED backlights



LIGHTING

Contents

1	GENERAL INFORMATION	3
1.1	Disclaimer	3
1.2	Forbidden use	3
1.3	Revisions	4
1.4	Ordering code	5
2	WARRANTY AND CERTIFICATIONS	6
2.1	Warranty	6
2.2	CE Declaration	6
2.3	FCC Declaration	6
2.4	RoHS, REACH and WEEE	7
2.5	Product EoL (end-of-life) handling	7
3	INTRODUCTION	8
3.1	Manual and conventions	8
3.2	Product identification data	8
3.3	Storage and use conditions	9
3.3.1	Storage conditions	9
3.3.2	Operating conditions	9
3.4	Photobiological safety	10
3.5	Cleaning and maintenance	12
4	GETTING STARTED	13
4.1	Overview	13
4.2	Accessories	13
5	TECHNICAL SPECIFICATIONS	15
5.1	LED color	15

5.2	Connectors and pinout	17
5.3	Electrical specifications	18
5.4	Electrical protections	18
5.5	Thermal protection	18
5.6	Operating modes	19
5.6.1	Continuous mode	20
5.6.2	Boosted mode	21
5.6.3	Strobe mode	22
5.6.4	Signal timing	24
5.6.5	Analog regulation use	25
5.7	Status LED	26
5.8	I/O circuitry	27
5.8.1	NPN input	27
5.8.2	PNP input	28
5.8.3	Analog dimming input	29

1 GENERAL INFORMATION

1.1 Disclaimer

Always use and store Opto Engineering® products in the prescribed conditions in order to ensure their proper operation: failing to comply with the prescribed conditions may shorten the product lifetime and/or result in malfunctioning, performance degradation or failure.

Be aware that incorrect operation of this equipment may cause dangerous situations or significant financial losses. It is essential that the users ensure that the operation of the product is suitable for their applications.

All trademarks mentioned herein belong to their respective owners.

Except where prohibited by law:

- All hardware, software and documentation are provided on an "as is" basis.
- Opto Engineering® accepts no liability for consequential loss, of any kind.

Upon receiving your Opto Engineering® product, visually examine it for any damage that could be occurred during shipping. If the product is damaged upon receipt, please notify Opto Engineering® immediately.

1.2 Forbidden use

Please read the following notes before using this product.
Contact your distributor or dealer for any doubts or further advice.

- Do not disassemble, modify or repair the product yourself. It may cause permanent malfunctioning, fire hazard or electric shock, possibly resulting in serious injury;
- Do not place the product in dusty, humid or hot places or near flames. These conditions may cause malfunctioning and damage, fire or electric shock, possibly resulting in serious injury;
- Do not spray or apply pesticides or other volatile chemicals on or in the proximity the product;
- This device must not be used in applications where its failure could pose a safety hazard or damage to other equipment. Keep in mind that if the device is used in a manner not foreseen by the manufacturer, the protection provided by its circuits and by its enclosure may be impaired;
- This is a low voltage device. As such, the voltage between any combination of applied signals must not exceed the supply voltage at any time;
- Higher voltages may cause a fault and could pose a safety hazard;

- This device has limited protection against transients caused by inductive loads. If necessary, use external protection devices like fast diodes or other specific transient protectors;
- Do not allow foreign objects to enter the unit or drop into holes, terminals and other openings or gaps. This may cause fire or electric shock, possibly resulting in serious injury;
- Disconnect the power cable before moving the product. Failure to comply with this precaution may damage the power cable or cause fire or electric shock, possibly resulting in serious injury;
- Do not scratch, cut, open or twist the power cables. It may cause malfunctioning, fire or electric shock, possibly resulting in serious injury;
- If the power cable is damaged or cracked, please contact our technical support and do not use the product. Damaged cables may cause malfunctioning, fire or electric shock, possibly resulting in serious injury;
- Do not insert or remove the plug of the power cable with wet hands. It may cause electric shock, possibly resulting in serious injury;
- Do not use the product in presence of flammable gas. It may cause outbreaks and flames, possibly resulting in serious injury;
- If you notice any abnormality such as smell, smoke or overheating, turn off the power and disconnect the power cables. Continuing to use the product in these conditions may cause fire or electric shock, possibly resulting in serious injury;
- If you have dropped the product or damaged the product case, turn off the power and disconnect the power cables. Continuing to use the product in these conditions may cause fire or electric shock, possibly resulting in serious injury.

1.3 Revisions

In Table 1 are listed all the user manual revisions.

In the column *Description* are listed all the relevant differences between different revisions.

Rev.	Date	Description
1.0	07/02/2024	First manual release
1.1	14/06/2024	Added tables with input voltage values
1.2	13/03/2025	Status LED legend updated

Table 1: Manual revisions

1.4 Ordering code

The product part number is composed as follows:

LT3BCZZZYYY-X

where ZZZ is the label of the illumination area height, YYY is the label of the illumination area width and X is the label of the color variant. The ordering code is explained more precisely in Table 2.

	YYY→	050	100	150	200	250	300	400	500
ZZZ↓	SIZE	50 mm	100 mm	150 mm	200 mm	250 mm	300 mm	400 mm	500 mm
050	50 mm								
100	100 mm								
150	150 mm								
200	200 mm								
250	250 mm								
300	300 mm								
400	400 mm								
500	500 mm								

Code	Description	Options	Value
X	LED color	W	white, 5700 K
		R	red, 625 nm
		G	green, 525 nm
		B	blue, 450 nm
		IR850	IR, 850 nm

Table 2: Ordering code. The highlighted cells are the available combinations of ZZZ (illumination area height) and YYY (illumination area width). The color label is X.

2 WARRANTY AND CERTIFICATIONS

2.1 Warranty

The device warranty is 12 months from the effective delivery date with reference to the device serial number.

Warranty covers the replacement or the repair of the defective part (components, device or part of it) with the exclusion of dismantling and shipping costs.

The replacement of one or more components does not renew the warranty period of the entire device.

The electronics and parts subjected to normal use or deterioration due to atmospheric agents and external environment are excluded from the warranty. Also, all failure caused by the lack of, insufficient or incorrect maintenance performed by unskilled or unauthorized personnel or due to unintended use or unauthorized replacements, alterations or repairs is excluded from the warranty.

The general validity of the warranty depends on:

- Maintenance being performed correctly as described in the device manual;
- The intended use of the device as specified in this manual.

2.2 CE Declaration

The LT3BC family is conformal to the EMC directive 2014/30/EU and therefore comply with the following standards:

Standard	Date of issue	Description
EN 61326-1	2013	Electrical equipment for measurement, control and laboratory use - EMC requirements
EN 62471	2008	Photobiological safety of lamps and lamp systems

2.3 FCC Declaration

This equipment has been tested and found to comply with the limits for a Class B digital device, pursuant to part 15 of the FCC Rules. These limits are designed to provide reasonable protection against harmful interference in a residential installation. This equipment generates, uses and can radiate radio frequency energy and, if not installed and used in accordance with the instructions, may cause harmful interference to radio communications. However, there is no guarantee that interference will not occur in a particular installation. If this equipment does cause harmful interference to radio or television reception, which can be determined by turning the equipment off and on, the user is encouraged to try to correct the interference by one or more of the following measures:

- Reorient or relocate the receiving antenna.
- Increase the separation between the equipment and receiver.
- Connect the equipment into an outlet on a circuit different from that to which the receiver is connected.
- Consult the dealer or an experienced radio/TV technician for help.

2.4 RoHS, REACH and WEEE

LT3BC products are conformal to the following directives and standards:

- RoHS 2011/65/EU
- REACH 1907/2006/EC
- WEEE 2012/19/EU

2.5 Product EoL (end-of-life) handling

Observe the following guidelines when recycling this equipment or its components. Production of this equipment required the extraction and use of natural resources. The equipment may contain substances that could be harmful to the environment or human health if improperly handled at the product's end of life. In order to avoid release of such substances into the environment and to reduce the use of natural resources, we encourage you to recycle this product in an appropriate system that will ensure that most of the materials are reused or recycled appropriately.

3 INTRODUCTION

3.1 Manual and conventions

Opto Engineering® SpA, with its registered office in Strada Circonvallazione Sud 15, 46100 Mantova (Mn) - Italy, hereinafter the manufacturer, provides all the necessary information in this installation, use and maintenance manual in a clear and simple way to install, use and service the LT3BC products.

The recipients of this manual are all those who have the knowledge, experience and capability of understanding the standards, prescriptions and safety measures indicated in this manual. Such people will be later identified as qualified personnel who are authorized to transport, install, use and service the products described in this manual.

This material can only be used by the customer whom this manual has been delivered to, in order to install, use and service the product.

The manufacturer will retain the right to modify or improve the manual and/or the product referred to in this manual without any prior notice.

The following typographical conventions are used in this document:

NOTE: notes contain important information. Highlighted outside the text to whom they refer



CAUTION: these indications highlight procedures that, if not observed in their entirety or in part, can cause damage to the machine or to the appliances



HAZARD: these indications highlight procedures that, if not observed in their entirety or in part, can cause injuries or affect the health of the operator

3.2 Product identification data

LT3BC LED backlights are identified with a label placed on the lateral side of the packaging box and on the back side of the cable tag, attached to the product.

This label is used to identify the part number and serial number of the product and contain some basic information on power consumption and current draw. A box label example is shown in Figure 1. A cable tag label example is shown in Figure 2.

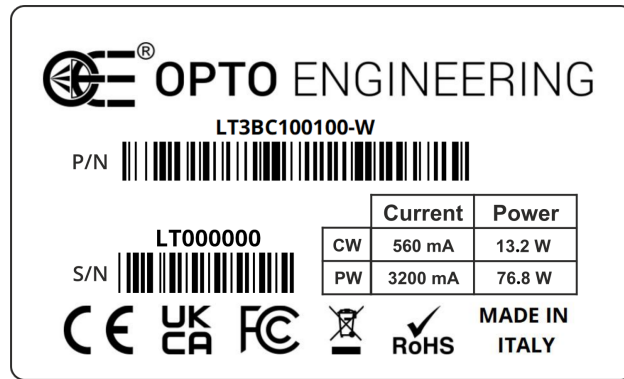

Figure 1: Example of box label.

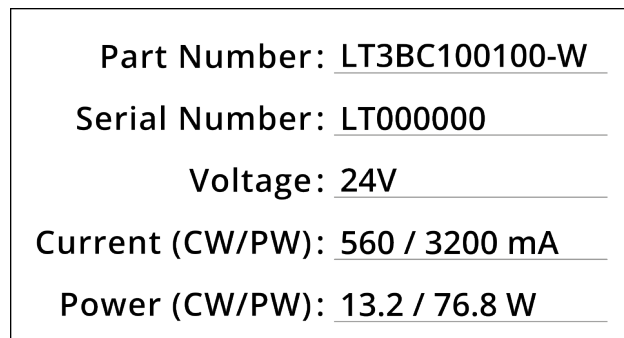

Figure 2: Example of cable tag label.

3.3 Storage and use conditions

3.3.1 Storage conditions

Avoid thermal shock by not exposing the product to sudden changes in temperature. Store the product in a dry place: storage environment with relative humidity (RH) less than 80% (no condensation).

3.3.2 Operating conditions

Extreme temperatures affect the product functionality, compromising LED irradiance and lifetime. Avoid any thermal shock and exposure of the product to sudden changes in temperature. The product includes high power LEDs: it's very important to dissipate an appropriate amount of

heat (if necessary, operate the device with a forced air cooling system).

Environment specifications	Values
Operating temperature	0-40 °C
Storage temperature	0-50 °C
Operating temperature humidity	20-85%, non condensing
Installation	Indoor use only
IP rating	IP54

Table 4: Environment operating specifications.

In general, avoid to store and use the product in the following environments:

- Environments with strong electric/magnetic fields.
- Places exposed to direct sunlight, rain or snow.
- Environments exposed to particular gas and dangerous substances.
- Extremely vibrating systems.
- Dusty places.
- Extremely humid places.
- Excessive hot/cold environments.



CAUTION: Product case temperatures can highly differ in case of poor heat dissipation. The product implements a thermal shutdown protection in order to avoid excessive damage to the internal electronics.



CAUTION: If used outside of the specified temperature range, the expected life of the product might consistently decrease. Opto Engineering® will not be responsible for product life reduction due to excessive thermal stress.

3.4 Photobiological safety

LT3BC series has been tested against EN 62471:2008 (photobiological safety of lamps and lamp system). The norm classifies LED lightings in 4 distinct groups, according to their hazardousness

LT3BCZZZYYY	Color Variant	Risk Group
$ZZZ+YYY \leq 200$		
	-W -R -G -B -IR850	Exempt Exempt Exempt Continuous: 1 Strobe: Exempt Exempt
$200 < ZZZ+YYY \leq 600$		
	-W -R -G -B -IR850	Exempt Exempt Exempt Continuous: 1 Strobe: Exempt Continuous: 1 Strobe: Exempt
$ZZZ+YYY > 600$		
	-W -R -G -B -IR850	Exempt Exempt Exempt Continuous: 1 Strobe: Exempt Continuous: 1 Strobe: Exempt

Table 5: EN62471 risk group of LT3BCZZZYYY-X (see Section 1.4).

degree. For LT3BC series, the risk group is reported in Table 5.

3.5 Cleaning and maintenance

When cleaning the product, please remember:

- To avoid disassembling the product.
- To avoid liquids or inappropriate cleaning chemicals like benzene, alcohol, spray-like cleaners.
- To use an appropriate soft cloth or soft brush.

The opaline of the product can be cleaned using compressed air or a cotton swab soaked with isopropyl alcohol.

4 GETTING STARTED

4.1 Overview

LT3BC products are **high power LED backlights** with integrated electronics. LT3BC LED backlights are designed to operate in both continuous and pulsed mode with an easy hardware interface. Also the boosted mode is allowed, which offers the possibility to have increased continuous power delivered for a time duration up to 60 s.

4.2 Accessories

As schematized in Table 6 and in Figure 3, linear polarizing filters, a couple of collimating filters or a transparent protection can be supplied as additional accessories. The accessories are provided with transparent Plexiglass covers to be mounted to the frontal with the corresponding screws, also included. The technical specifications of the accessories are summed in Table 7 and Table 8.

Code	Description
PLLT3BCZZZYYY-H	Additional Protection (3 mm Transparent Plexiglass + Horizontal Polarizing Filter + screws)
PLLT3BCZZZYYY-V	Additional Protection (3 mm Transparent Plexiglass + Vertical Polarizing Filter + screws)
CLLT3BCZZZYYY	Additional Protection (3 mm Transparent Plexiglass + Collimating Filters + screws)
PCLT3BCZZZYYY	Additional Protection (3 mm Transparent Plexiglass + screws)

Table 6: Additional accessories of the device LT3BCZZZYYY according to the legend in Section 1.4.

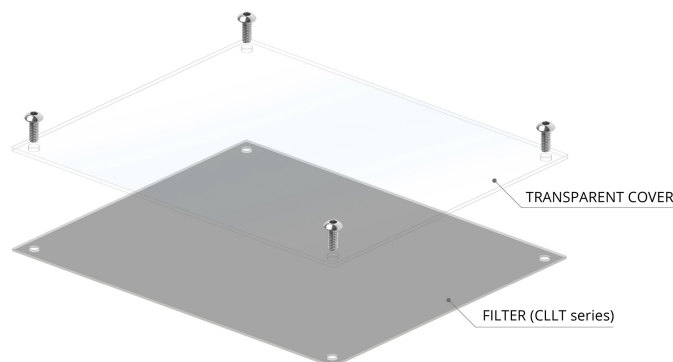

Figure 3: Example of the accessory filter with the transparent cover in Plexiglass and screws.

Parameters	Value
Thickness	0.7 mm
Transmission	42 % \pm 2 %
Degree of polarization	99.98%
Inverse of Extinction Ratio	< 0.01%
Spectral range	380 – 780 nm

Table 7: Technical specifications of the additional accessory polarizing filters PLLT3BC-H and PLLT3BC-V. Notice that the polarizing filter is not available for the LT3BCZZZY-IR850 models and for the models with ZZZ,YYY \geq 400.

Parameters	Value
Thickness	0.57 mm
Light transmittance	30%
Reflectivity	3 – 6%
Visual angle	15° \pm 5°

Table 8: Technical specifications of the two additional accessory collimating filters CLLT3BC. The values are referred to the single filter but always two of them are mounted together.

5 TECHNICAL SPECIFICATIONS

5.1 LED color

The product is available with different LED color options depending on the specific model. In Table 9 you will find the correspondence between the model suffix and the color with its peak wavelength. The spectra of the available models are presented in Figure 4.

Model suffix	Color
-W	White, 5700 K
-R	Red, 625 nm
-G	Green, 525 nm
-B	Blue, 450 nm
-IR850	IR, 850 nm

Table 9: Model suffix and corresponding colors.

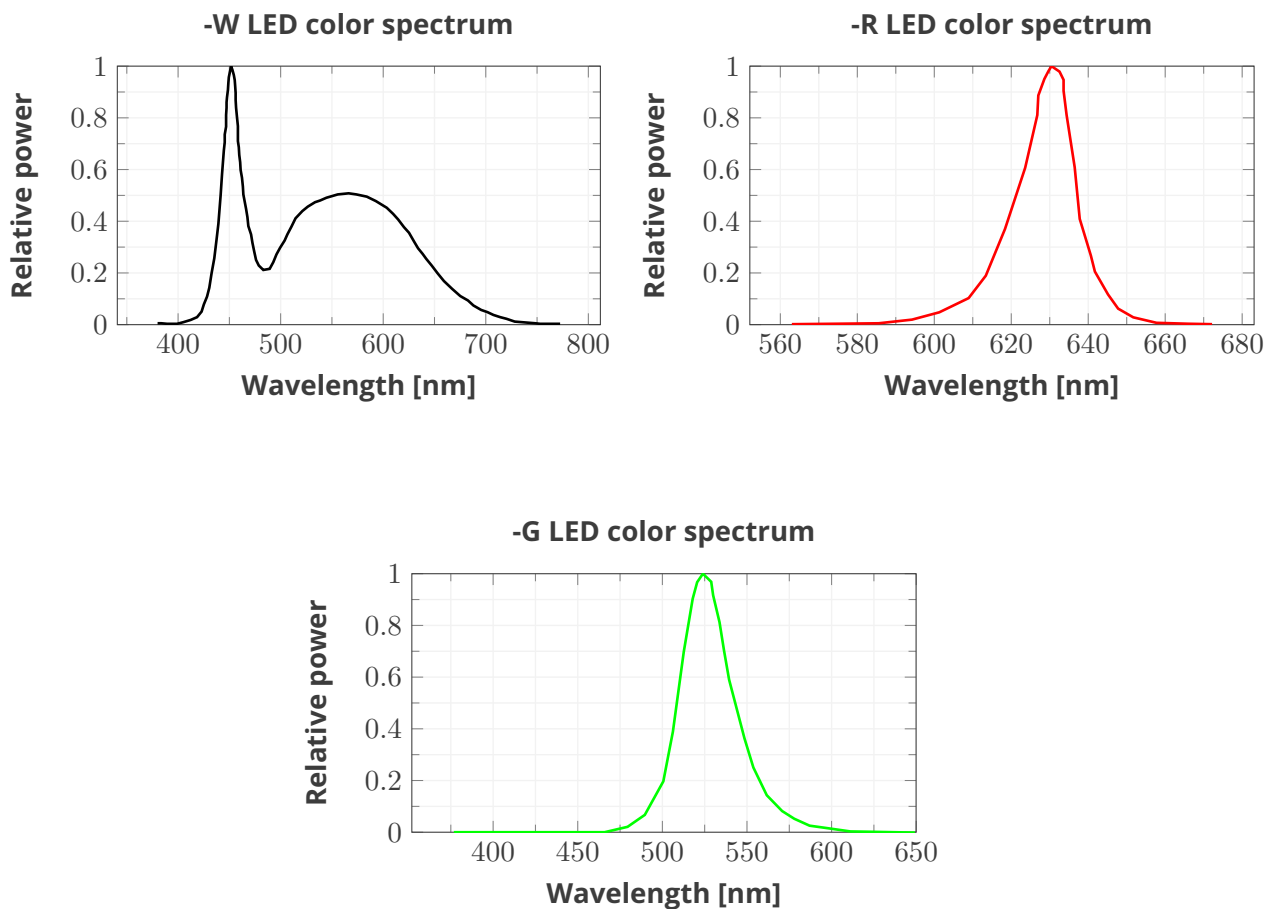

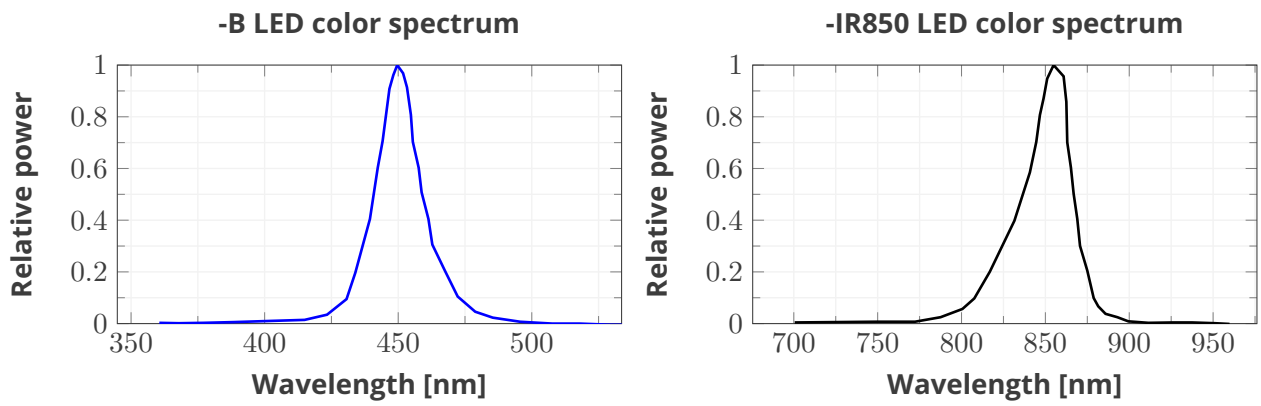

Figure 4: LED's emission spectrum of each color model.

5.2 Connectors and pinout

The M12 straight plug male connector is schematized in Figure 5 in order to show the 5 pins. The functionality of the pins are shown in Table 10.

It is important to notice that the variants with $ZZZ \geq 300$ or $YYY \geq 300$ (see Section 2) exhibit two connectors. Furthermore the variant LT3BC500500 exhibit three connectors. In all cases, the only connector used both for power supply and for the input signal to the controller is the one with the external label, while any others need only be connected for power supply (Pin 1) and ground (Pin 3).

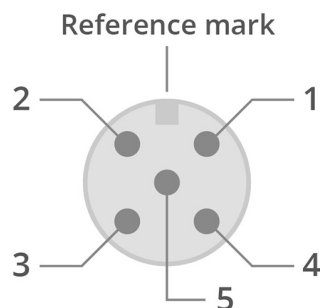

Figure 5: Scheme of the connector pinout (device side).

Pin	Standard
1	Power +24 V _{dc}
2	NPN
3	GND
4	PNP
5	Analog dimming

Table 10: Connector pinout.

NOTE: It is strongly recommended to use same length cables for the models that require two or more power inputs.



CAUTION: The device can be damaged if the wrong connections are made.



CAUTION: For models that require two or more power inputs, ensure to connect all power cables to the same power supply source.

5.3 Electrical specifications

The voltage supported by the pins in Figure 5 for the standard variant device are:

Pin	Voltage
1: Power	+26 V (Maximum Working voltage), +30 V (Absolute Maximum Ratings)
2: NPN	±9 V (Absolute Maximum Ratings)
3: GND	Ground
4: PNP	±27 V (Absolute Maximum Ratings)
5: Analog	±27 V (Absolute Maximum Ratings)

Table 11: Voltage supported by the connector pins.



HAZARD: Do not exceed the recommended voltages! Risk of damage to the device and danger for the operator.

5.4 Electrical protections

The signal inputs Pin 3, Pin 4, Pin 5 feature ESD protection, while the power supply input (Pin 1 in Table 10) exhibits reverse polarity protection.

5.5 Thermal protection

The temperature of the device is continuously monitored by a temperature sensor placed near the LEDs. If the maximum temperature $T_{max} = 80^{\circ} \text{C}$ is reached, then the thermal shutdown occurs. The system reactivates when the temperature decreases by the amount given by the hysteresis temperature $\Delta T_{hyst} = 20^{\circ} \text{C}$, namely for $T < 60^{\circ} \text{C}$.

5.6 Operating modes

The LEDs can operate in three different modes: the *continuous mode*, the *boosted mode* and the *strobe mode* that are schematized in Figure 6 and described more precisely in the following sections.

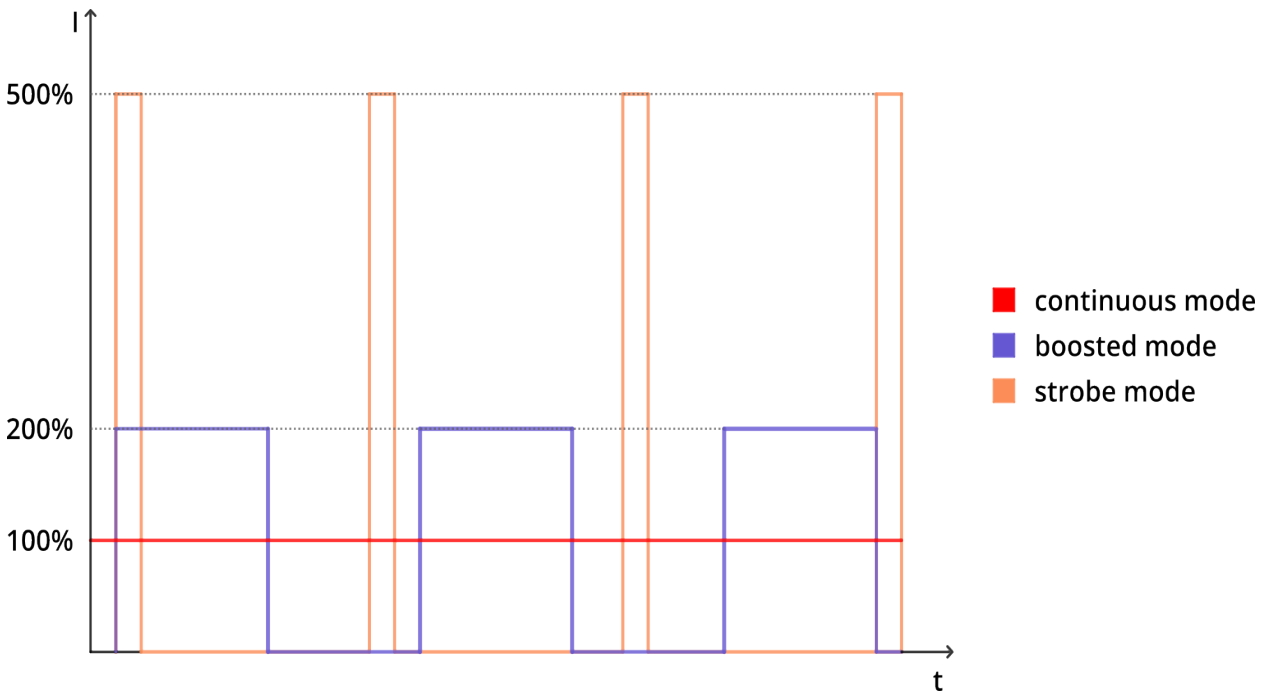

Figure 6: LED power delivered in the three modalities. The time scale of the strobe mode is different from the other ones.

5.6.1 Continuous mode

Continuous operations are available with the possibility of delivering continuous electrical power on the LED.

In order to select the 100%-continuous mode, there are two different options:

1. the pin NPN must be kept at $V_{NPN} \leq 1 \text{ V}$
2. the pin PNP must be kept at $V_{PNP} > 3 \text{ V}$

Take into account the fact that for the first 10 ms of the input signal, the output of the LEDs is equal to the one in strobe mode, then the true continuous mode is activated (see Figure 7). Finally, please refer to Section 5.6.5 for the analog regulation of the delivered power.

Pin	Voltage
1: Power	+24 V
2: NPN	Start: $0 < V_{NPN} < 1 \text{ V}$
3: GND	Ground
4: PNP	-
5: Analog	-

Pin	Voltage
1: Power	+24 V
2: NPN	-
3: GND	Ground
4: PNP	Start: $3 < V_{PNP} < 24 \text{ V}$
5: Analog	-

Table 12: In order to select the continuous mode two equivalent options are possible.

5.6.2 Boosted mode

In boosted mode, the LEDs are allowed to be slightly overpowered compared to the continuous mode (200% of the power), forcing a use with shutdown after a time interval on the order of 30 – 60 s to avoid excessive overheating of the device.

In order to select the boosted mode, provided that the PIN 5 (analog input) must be kept always at $V_{in} = 24\text{ V}$, there are two different options:

1. the pin NPN must be kept at $V_{NPN} \leq 1\text{ V}$; $V_{in} = 24\text{ V}$
2. the pin PNP must be kept at $V_{PNP} > 3\text{ V}$; $V_{in} = 24\text{ V}$

Please, refer to Section 5.6.4 for the signal timing parameters.

Pin	Voltage
1: Power	+24 V
2: NPN	Start: $0 < V_{NPN} < 1\text{ V}$
3: GND	Ground
4: PNP	-
5: Analog	$V_{in} = +24\text{ V}$

Pin	Voltage
1: Power	+24 V
2: NPN	-
3: GND	Ground
4: PNP	Start: $3 < V_{PNP} < 24\text{ V}$
5: Analog	$V_{in} = +24\text{ V}$

Table 13: In order to select the boosted mode two equivalent options are possible.



CAUTION: When not dissipated, it is mandatory to comply with the maximum limits set in Section 5.6.4 in order to avoid overheating and subsequent de-rating of the LEDs.

5.6.3 Strobe mode

Operations in strobe mode are available with the possibility of delivering pulsed electrical power on the LEDs (about 500% of peak power with respect to the continuous mode power).

When $V_{NPN} \leq 1\text{ V}$ or $V_{PNP} > 3\text{ V}$, the LEDs are turned on for a time duration that corresponds to the trigger pulse duration. At the end of the trigger pulse, the minimum T_{off} timer is automatically modulated based on the duty cycle values to comply with the maximum limits set (Section 5.6.4). Therefore, each successive pulse that is sent to the device before this T_{off} has elapsed since the end of the previous one will be ignored. In the case of input pulses that occur before the minimum T_{off} has elapsed, the status LED will turn red for 1 second, but the device will not go into an error state.

If maximum T_{on} times are exceeded, the illuminator automatically reduces power to avoid compromising the life of the LED as schematized in Figure 7.

Please refer to Section 5.6.4 for the signal timing parameters.

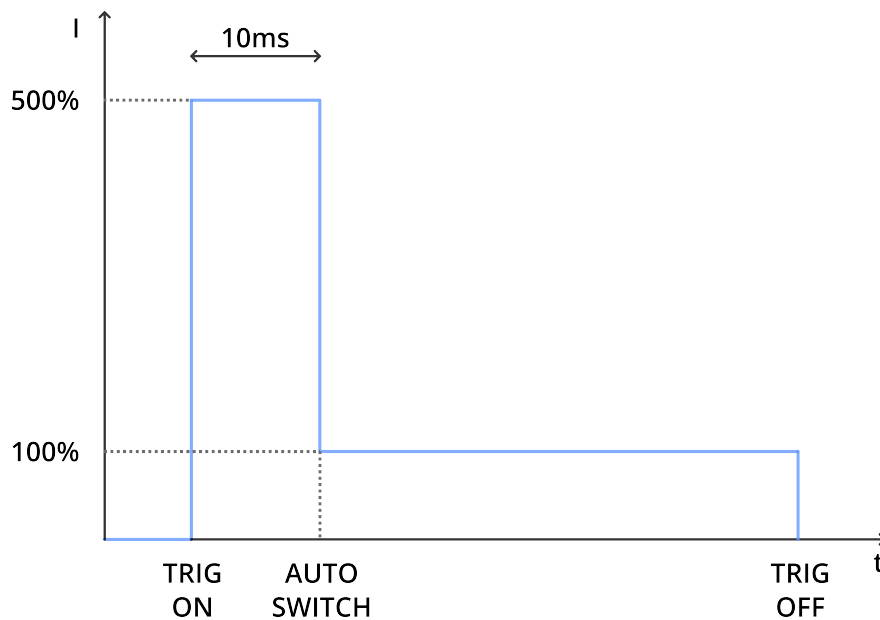

Figure 7: The auto-switch is activated when the maximum $T_{on} = 10\text{ ms}$ is reached.

Pin	Voltage
1: Power	+24 V
2: NPN	Start: $0 < V_{NPN} < 1$ V (for pulse duration)
3: GND	Ground
4: PNP	-
5: Analog	-

Pin	Voltage
1: Power	+24 V
2: NPN	-
3: GND	Ground
4: PNP	Start: $3 < V_{PNP} < 24$ V (for pulse duration)
5: Analog	-

Table 14: In order to select the strobe mode two equivalent options are possible.

5.6.4 Signal timing

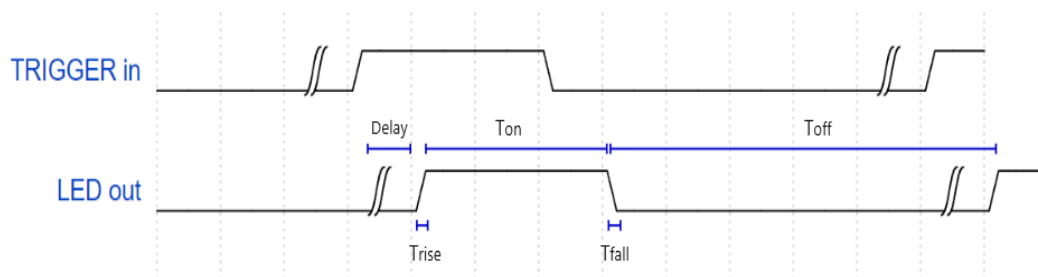

Figure 8: Scheme of the input trigger signal and of the corresponding LED output.

For strobe mode and boosted mode, let's refer to Figure 8 for the definitions of T_{on} and T_{off} . The period is $T = T_{on} + T_{off}$. The duty cycle is: $\text{Duty Cycle} = T_{on}/T$.

In Figure 8 it is also possible to see the scheme of the time delay of the LED output response with respect to the trigger signal, the time T_{rise} needed for the LED output to reach the maximum voltage value and the time T_{fall} needed for the output to drop to zero.

The timer resolution is 10 ns, and the delay jitter, i.e. the repetition uncertainty on the time delay, results to be 10 ns.

All the aforementioned parameters are summed in Table 15.

Parameters	Value
T_{on}^{min}	3 μs
T_{on}^{max}	10 ms (strobe mode) 60 s (boosted mode)
Timer resolution	10 ns
Duty cycle max	10% (strobe mode) 50% (boosted mode) ¹
$T_{rise} + \text{Delay}$	300 ns
T_{fall}	400 ns
Delay jitter	10 ns

Table 15: Signal timing parameters for strobe mode and boosted mode.

¹In boosted mode the T_{off} time is NOT automatically handled. To use it as continuous mode with maximum Duty Cycle from 51% to 100%, it is necessary to use the heat sink or forced ventilation to avoid overheating.

5.6.5 Analog regulation use

The electrical power delivered on the LED in continuous mode can be regulated with power modulation 0 – 100% by means of the connection of the Pin 5 (analog input) to an input voltage $V_{in} = 1 - 10$ V, without using the PNP and NPN input signals. The behavior of the power delivered as a function of the corresponding input voltage is depicted in Figure 9.

Notice that for $V_{in} < 1$ V the analog regulation is not active, while for $V_{in} > 20$ V the boosted mode is activated, so that the mentioned regimes require instead the PNP or the NPN input signal.

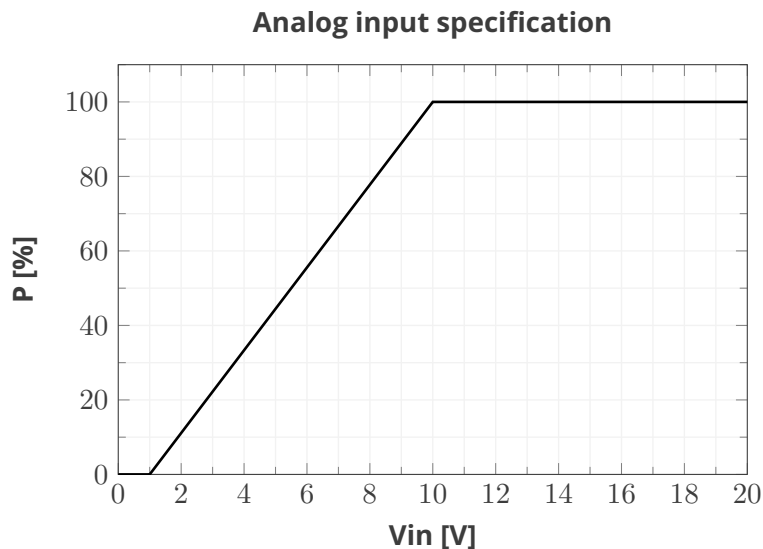

Figure 9: Percentage LED power as a function of the analog input voltage in continuous mode with analog regulation. The percentages are referred to the maximum power delivered on the LED for the continuous mode. The boosted mode is activated for $V_{in} > 20$ V while for $V_{in} < 1$ V the analog regulation is simply not activated.

Pin	Voltage
1: Power	+24 V
2: NPN	
3: GND	Ground
4: PNP	-
5: Analog	1-10 V (0-100% power)

Table 16: In order to select the analog regulation use mode there is no need of input signal at Pins 2 (NPN) and 4 (PNP). Only the analog input voltage $V_{in} = 1 - 10$ V will result in a modulation from 0 to 100% in the output power.

5.7 Status LED

A RGB-LED, placed on the outer surface of the device, indicates the system status with the following color legend.

Color	Status
● Orange	Idle (for all modalities: power supply on, but no inputs)
● Green	PNP/NPN active (for continuous mode and for strobe mode during the pulse)
● Purple	Boosted mode active (i.e. $V_{in} = 24\text{ V}$; $V_{NPN} \leq 1\text{ V}$ or $V_{PNP} > 3\text{ V}$)
● Red	Generic error state ²
● Red blink	Over temperature

Table 17: Color legend of the status RGB-LED.

²In strobe mode, if input pulses occur before the minimum T_{off} has elapsed, the status LED will turn red for 1 second as a warning to the user, but the device will not go into an error state, but will simply discard pulses until the minimum T_{off} expires.

5.8.2 PNP input

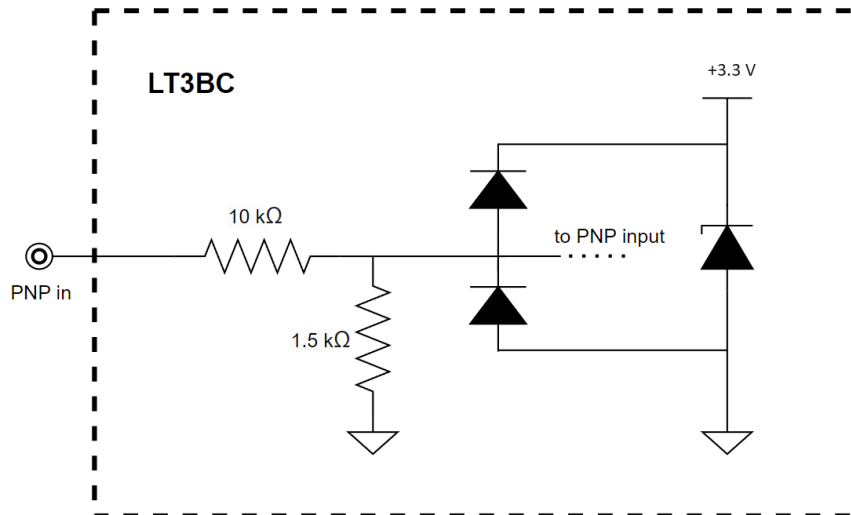

Figure 11: Scheme of the PNP input.

The PNP logic input scheme is depicted in Figure 11. Please note that the PNP input is a current sink with respect to the controller connected.

5.8.3 Analog dimming input

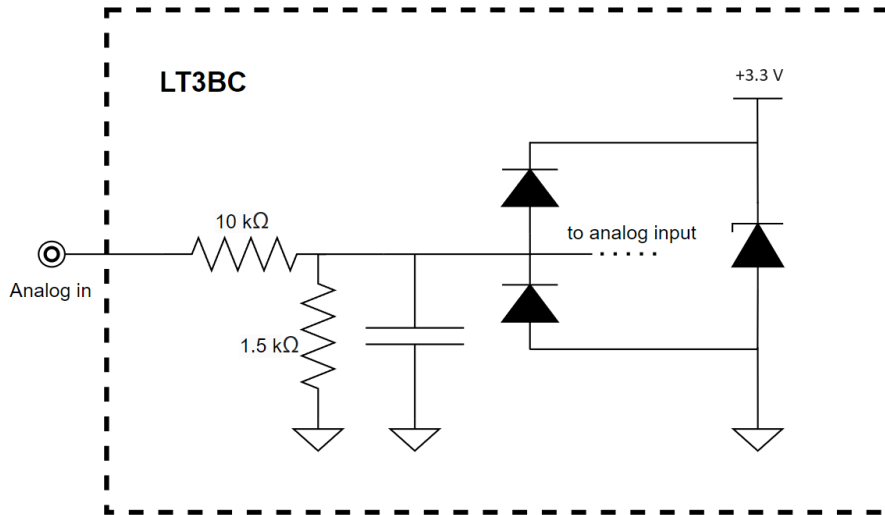
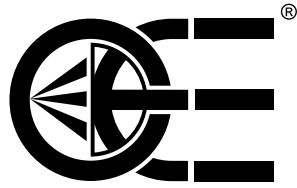

Figure 12: Scheme of the analog dimming input.

The analog dimming input scheme is depicted in Figure 12. The DC input impedance is $Z_{In} = 11.5 \text{ K}\Omega$. A low-pass filter (cut-off frequency $f_c \approx 2.34 \text{ KHz}$) cuts high-frequency input signals.



OPTO ENGINEERING

Contact us

EUROPE

**Opto Engineering
Headquarters**

str. Circonvallazione Sud, 15
46100 Mantova, IT
phone: +39 0376 699111
eu@opto-e.com

**Opto Engineering
Germany**

Marktplatz 3,
82031 Grünwald, DE
phone: +49 (0)89 693 9671-0
de@opto-e.com

UNITED STATES

**Opto Engineering
USA**

11321 Richmond Ave
Suite M-105, Houston, TX 77082, USA
phone: +1 832 2129391
us@opto-e.com

ASIA

**Opto Engineering
China**

Room 1903-1904, No.885, Renmin RD
Huangpu District 200010
Shanghai, CN
phone: +86 21 61356711
cn@opto-e.com