

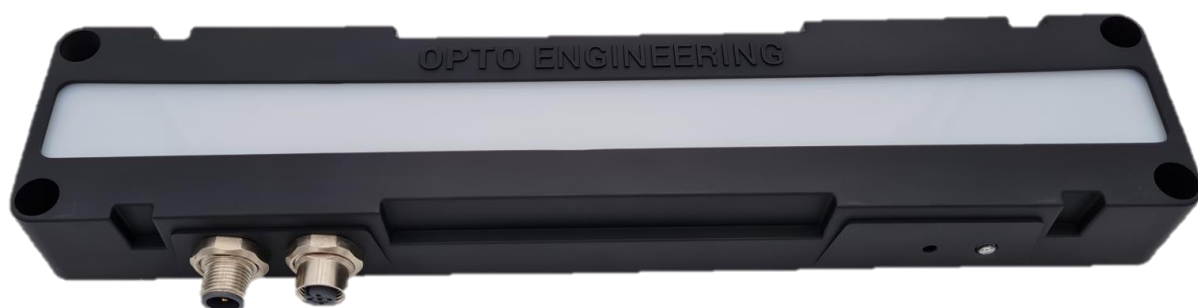

OPTO ENGINEERING



INSTRUCTIONS MANUAL

LTBRZ3 series

LED bar lights with integrated driving electronics



Summary

1.	Disclaimer	3
2.	Safety notes.....	3
3.	Eye safety	4
4.	Product EoL (end-of-life) handling	4
5.	Unpacking.....	5
6.	Cleaning and maintenance	5
7.	Product warranty	5
8.	Environment.....	5
9.	General description.....	6
10.	Electrical specifications.....	6
10.1	Illuminator connectors and daisy chain option.....	6
10.2	Cables.....	9
10.3	Power supply for LTBRZ3-C series	11
10.4	Power supply for LTBRZ3-P series.....	12
10.5	Enable signals.....	13
10.6	Timing performance of LTBRZ3-C	14
10.7	Timing performance of LTBRZ3-P.....	15
10.8	Dimming	18
10.9	Led indicator.....	20
10.10	Optical layout and performances	22
10.10.1	Led color options	22
10.10.2	Lens options.....	24
10.10.3	Polarizer options	30
10.10.4	Illuminance/irradiance data.....	32
10.10.5	Led current ripple of LTBRZ3-C.....	35
11.	Dimensions.....	36
12.	Electromagnetic compatibility.....	36
13.	Revision hystory	37

1. Disclaimer

Always deploy and store Opto Engineering products in the prescribed conditions in order to ensure proper functioning. Failing to comply with the following conditions may shorten the product lifetime and/or result in malfunctioning, performance degradation or failure.

Ensure that incorrect functioning of this equipment cannot cause any dangerous situation or significant financial loss to occur. It is essential that the user ensures that the operation of the controller is suitable for their application. All trademarks mentioned herein belong to their respective owners.

Except as prohibited by law:

- All hardware, software and documentation are provided on an “as is” basis Opto
- Engineering accepts no liability for consequential loss, of any kind
-

Upon receiving your Opto Engineering product, visually examine the product for any damage during shipping. If the product is damaged upon receipt, please notify Opto Engineering immediately.

2. Safety notes

Please read the following notes before using this controller. Contact your distributor or dealer for any doubts or further advice.

This device must not be used in an application where its failure could cause a hazard to human health or damage to other equipment. Keep in mind that if the device is used in a manner not foreseen by the manufacturer, the protection provided by its circuits and by its enclosure may be impaired.

This is a low voltage device. As such, the potential difference between any combination of applied signals must not exceed, at all times, the supply voltage. Higher voltages may cause a fault and can be dangerous to human health.

This device has limited protection against transients caused by inductive loads. If necessary, use external protection devices like fast diodes or, better, specific transient protectors.

When the device is switched off, there is still energy stored in the internal capacitors for at least five minutes.

When operating the illuminator at the maximum brightness it can get very hot. The illuminator should be positioned where personnel cannot accidentally touch it and away from flammable materials. Never exceed the power ratings stated in the manual.

During normal operation, the case temperature may exceed ambient temperature by as much as 25 °C (45 °F). To prevent higher case temperatures, the product can be fixed over a metal plate

3. Eye safety

LTBRZ3 Series has been tested against EN 62471:2008 (photobiological safety of lamps and lamp system). The norm classifies LED lightings in 4 distinct groups, according to their hazardousness degree. For LTBRZ3 series, the risk group is reported in the table below.

Part Number	Color	Hazard-related risk group	Guidance on control measurement
LTBRZ3-C-R Series	Red, 630 nm	Exempt	-
LTBRZ3-P-R Series	Red, 630 nm	Exempt	-
LTBRZ3-C-G Series	Green, 530 nm	Group 1	-
LTBRZ3-P-G Series	Green, 530 nm	Group 1	-
LTBRZ3-C-B Series	Blue, 470 nm	Group 1	-
LTBRZ3-P-B Series	Blue, 470 nm	Group 1	-
LTBRZ3-C-W Series	White, 6500 K	Group 1	-
LTBRZ3-P-W Series	White, 6500 K	Group 1	-
LTBRZ3-C-IR Series	Infrared, 860nm	Group 1	IR emitted from this product. Use appropriate shielding or eye protection
LTBRZ3-P-IR Series	Infrared, 860 nm	Exempt	-

Table 1: LTBRZ3 EN62471 risk group.

Important note: despite infrared light is invisible to the eyes, eye damage may occur. To know if the illuminator is ON, please refer to led indicator. In all cases, Opto Engineering recommends the use of protection glasses.

4. Product EoL (end-of-life) handling

Observe the following guidelines when recycling this equipment or its components. Production of this equipment required the extraction and use of natural resources. The equipment may contain substances that could be harmful to the environment or human health if improperly handled at the product's end of life. In order to avoid release of such substances into the environment and to reduce the use of natural resources, we encourage you to recycle this product in an appropriate system that will ensure that most of the materials are reused or recycled appropriately.



This symbol indicates that this product complies with the applicable European Union requirements according to the WEEE (Waste Electrical and Electronic Equipment) Directive 2012/19/EU

5. Unpacking

Products are packed in our factory, using suitable materials for a safe transport through the usual means of transportation, in Italy and internationally. However, a damaged package must be reported to the carrier on delivery.

To open the package, do not use any cutting blade to avoid product damaging.

6. Cleaning and maintenance

Important note: clean the product when it is unplugged or switched off.

Use a soft and dry cloth. Do not use any abrasive material. Do not use any cleaning solvent or aggressive chemical product.

For cleaning metal surfaces, we recommend to use isopropyl alcohol.

For cleaning acrylic, polycarbonate and plastic surfaces use an alcohol-free spray cleaner.

Cleaning with compressed air is not recommended.

7. Product warranty

The device warranty is 12 months from the effective delivery date with reference to the device serial number.

The warranty covers the replacement or repairs of the defective part (components, device or part of it) with the exclusion of dismantling and shipping costs.

The replacement of one or more components does not renew the warranty period of the entire device. The manufacturer cannot be held liable for any compensation for whatever reason and the buyer renounces any claims for costs or damages to third parties due to any machine downtime.

8. Environment

The following tables provides environmental specifications:

Feature	Specification
Operating temperature	0°C to 40°C
Storage temperature	0°C to 50°C
Relative humidity	20-85% non-condensing
IP class	IP40
Installation	Indoor use only

Operation outside the allowed temperature range can damage the product. For best performance and to protect the product from damage, keep the housing temperature in the specified operating temperature range.

Observe what follows:

- for maximum heat dissipation, affix the illuminator to a heat sink or to a metallic plate, using the 4 mounting holes;
- use mounting base and heat sink with large surface areas and high thermal conductivity;
- reduce ambient temperature, for example, shielding some heat sources;
- provide ventilation or other active cooling of illuminator, mounting base, and heat sink.

9. General description

The LTBRZ3 is a 300mm linear LED illuminator. LTBRZ3-C is designed for continuous mode operation and integrates a low ripple constant current driver. LTBRZ3-P is designed for pulsed operation (strobe mode) and uses a super-fast led driver. NPN or PNP triggers can be used to turn on and off the light. Light intensity can be adjusted by 0-10 VDC analog intensity line or set manually by an external accessible potentiometer. The LTBRZ3 can be connected forming a daisy-chain configuration composed by a maximum number of 4 modules.

10. Electrical specifications

10.1 Illuminator connectors and daisy chain option

The LTBRZ without daisy chain option is equipped with a single M12 A-type circular industrial male connector. With a single input connector, the product is design to operate as a stand-alone module. The single connector acts as input port for both power supply and control signals.

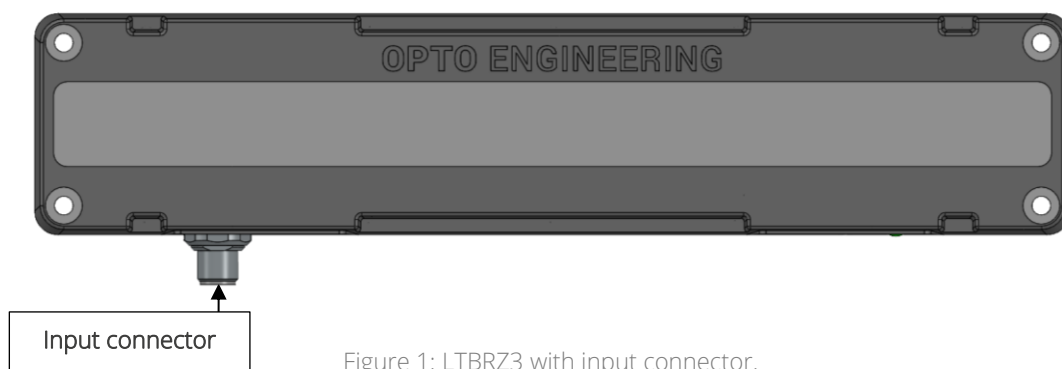

Figure 1: LTBRZ3 with input connector.

The LTBRZ with daisy chain option (-DC) is design to operate as stand-alone unit or connected together with multiple units. The product is equipped with two M12 A-type circular industrial connectors. The input connector is male, while the output connector is female. The purpose of the output connector is to let multiple units being connected together.

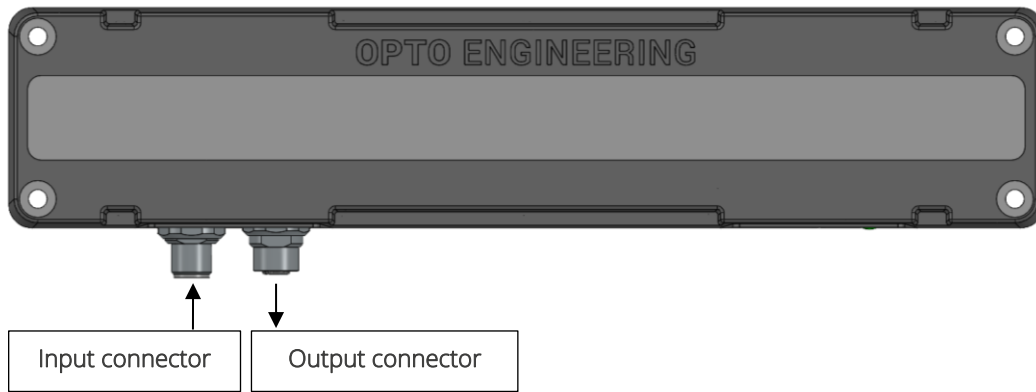

Figure 2: LTBRZ3 with input and output connectors.

Daisy-chain operation allows up to 4 modules to operate sharing both power and control signals. This operation mode has the purpose to save wiring complexity and optimize space and harness displacement.

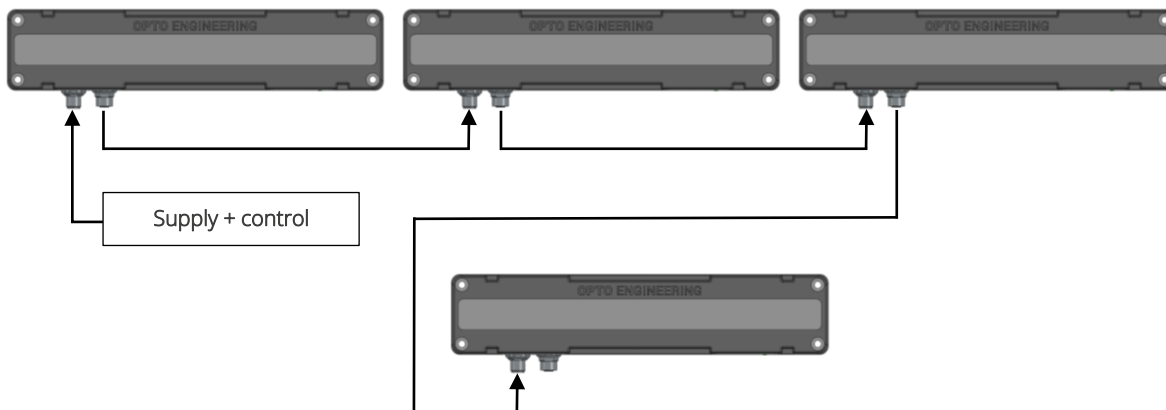

Figure 3: LTBRZ3 connection diagram for daisy-chain configuration.

The pinout of the M12 connectors is the same for each configuration and is reported in the drawing and table below. Output connector (right one) is physically present only if product has daisy-chain (-DC) option.

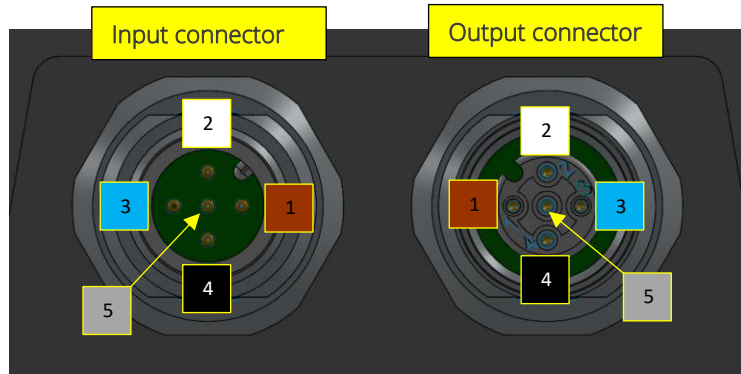

Figure 4: M12 input and output connectors pinout.

Pin #	Signal	Description	Mode	I/O cable color
1	Supply +24V	Power supply +24V	-	Brown
2	NPN Enable	NPN enable input	Active low	White
3	Supply GND	Power supply GND	-	Blue
4	PNP Enable	PNP enable input	Active high	Black
5	Analog dimming	Analog	0 to 10V	Grey or Green

Table 2: M12 connectors pinout and signals.

Important notes:

Do not use output connector as power and control source.

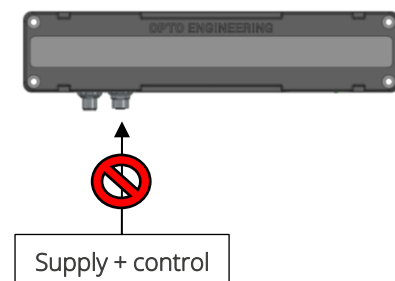
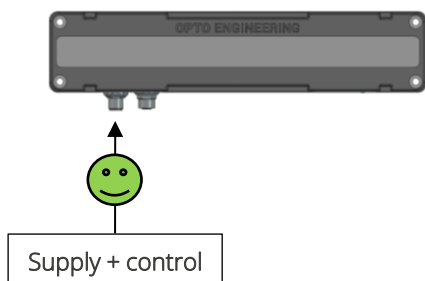

In daisy-chain configuration, do not connect more than 4 modules.

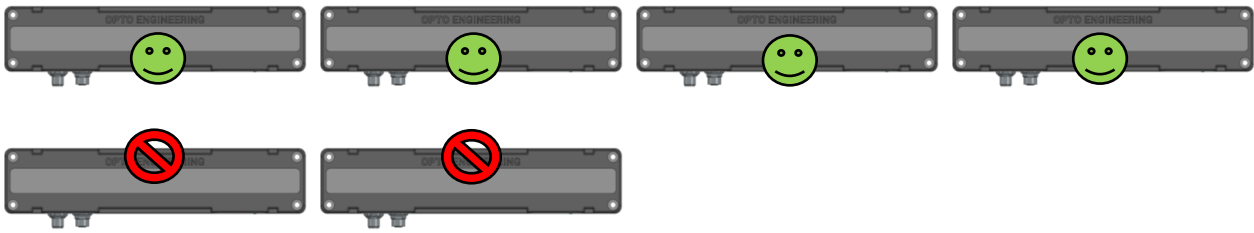

Without respecting these notes, product damage may occur and warranty will be void.

10.2 Cables

The illuminator is provided without cables. Appropriate cable must be ordered separately according to the tables below. Cables are different between LTBRZ3-C and LTBRZ3-P.

Part number	Description
CBLT014	Illumination cable PVC black, side 1 M12 female connector straight, side 2 cable end, 5 ways, 5m length
CBLT015	Illumination cable PVC black, side 1 M12 female connector right angled, side 2 cable end, 5 ways, 5m length
CBLT016	Illumination jumper cable PVC, side 1 M12 male connector straight, side 2 M12 female connector straight, 5 ways, 0.5m length
CBLT017	Illumination jumper cable PVC, side 1 M12 male connector straight, side 2 M12 female connector straight, 5 ways, 1m length
CBLT018	Illumination jumper cable PVC, side 1 M12 male connector straight, side 2 M12 female connector straight, 5 ways, 2m length

Table 3: available cable list for LTBRZ3-C

Part number	Description
CBLT020	Illumination cable PVC yellow, side 1 M12 female connector straight, side 2 cable end, 5 ways, 5m length, high current
CBLT021	Illumination cable PVC yellow, side 1 M12 male connector straight, side 2 M12 female connector straight, 5 ways, 1m length, high current

Table 4: available cable list for LTBRZ3-P

CBLT014 and CBLT015 are designed to be used for connecting the input port to the power supply and control unit and are suitable for LTBRZ3-C Series.

CBLT016, CBLT017, CBLT018 are designed to be used for connecting the output port of a module to the input port of another one (daisy-chain interconnection) and are suitable for LTBRZ3-C Series.

CBLT020 is designed to be used for connecting the input port to the power supply and control unit and is suitable for LTBRZ3-P Series.

CBLT021 is designed to be used for connecting the output port of a module to the input port of another one (daisy-chain interconnection) and is suitable for LTBRZ3-P Series.

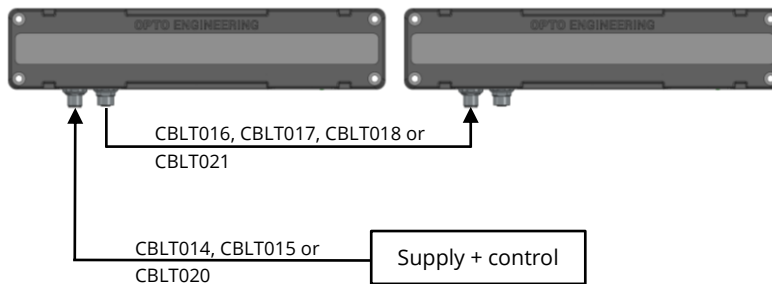

The following diagram details a typical configuration with 4 LTBRZ3-C modules, daisy-chain connected. The total length of the cable is 6.5 m and we recommend to consider this value as maximum.

The example is useful to evaluate voltage drop across the cables with the following hypothesis:

- DC power supply with a regulated output of 24.0V
- CBLT014 used as cable for Line1 (5 m length)
- CBLT015 as daisy-chain cable for Line2, Line3 and Line4 (0.5 m length)
- LTBRZ3-C operating at full brightness, 18 W max power consumption for each module

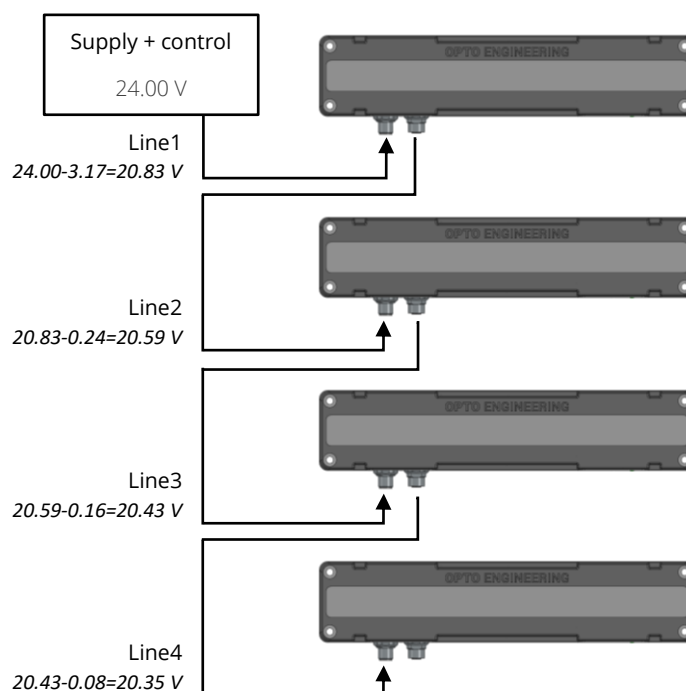

In case of longer power supply cable needed, increase the section of the copper wires, especially for the cable used for Line1. Please consider that CBLT014 ... CBLT018 are AWG22 (0.33 mm²). For improved immunity against external disturbance sources, use a single shielded cable, grounded at the end opposite to the illuminator.

Line number	Length	Power handled	Voltage drop over the line	Voltage at input port
Line1	5.0 m	18 W x 4 = 72 W	3.17 V	20.83 V
Line2	0.5 m	18 W x 3 = 54 W	0.24 V	20.59 V
Line3	0.5 m	18 W x 2 = 36 W	0.16 V	20.43 V
Line4	0.5 m	18 W	0.08 V	20.35 V

Table 4: typical power consumptions and voltage drop across cables with 4 daisy-chain connected modules.

Important note:

LTBRZ3 Series is equipped with a control circuit that monitors the power supply. This circuit turns the illuminator OFF if the Voltage detected at the input port reaches a threshold value of 17-18V, too low for a correct operation of the embedded led driver. In order to let the illuminator restart, the voltage must reach 19-20V. The diagram below shows the behavior.

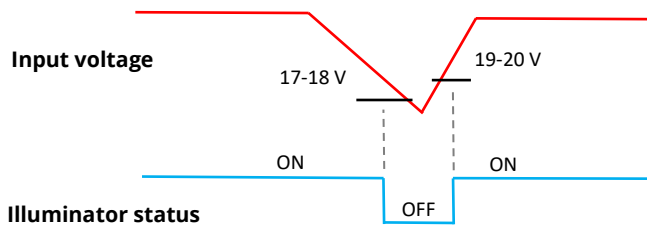

10.3 Power supply for LTBRZ3-C series

The power supply voltage must be 24V. A dedicated and well-regulated power supply is required. The external power supply must be capable of supplying the current required by the products and is dependent by how many modules are connected in daisy chain mode.

Parameter	Value
Power supply voltage	+24 Vdc (+/- 5%)
Power consumption	18 W max.
Current consumption	750 mA typ.

Table 5: supply requirements for a single unit of LTBRZ3-C.

When multiple illuminators are connected in daisy-chain configuration, please consider these values.

Parameter	Power supply current consumption		
	2 units	3 units	4 units
Power consumption	36 W max.	54 W max.	72 W max.
Current consumption	1.5 A typ.	2.25 A typ.	3.00 A typ.

Table 6: supply requirements for multiple units of LTBRZ3-C.

10.4 Power supply for LTBRZ3-P series

The power supply voltage must be 24V. A dedicated and well-regulated power supply is required. The external power supply must be capable of supplying the current required by the products and is dependent by how many modules are connected in daisy chain mode. Due to the high current pulsed operation mode, the peak power consumption can be very high, while the average current still remains at low value.

Parameter	Value
Power supply voltage	+24 Vdc (+/- 5%)
Peak power consumption	100 W max.
Peak current consumption	4A max.
Average power consumption with duty-cycle set to 10%	10W max.
Average current consumption with duty-cycle set to 10%	400mA max.

Table 7: supply requirements for a single unit of LTBRZ3-P.

When multiple illuminators are connected in daisy-chain configuration, please consider these values.

Parameter	Power supply current consumption		
	2 units	3 units	4 units
Peak power consumption	200 W max.	300 W max.	400 W max.
Peak current consumption	8 A typ.	12 A typ.	16 A typ.

Table 8: supply requirements for multiple units of LTBRZ3-P.

Please consider that when the LEDs of LTBRZ3-P are active and operating with long turn-on times and duty-cycles, only a small portion of the required energy is stored into the internal capacitors and that most of it is provided from the power supply. This must be taken into account dimensioning the power supply.

10.5 Enable signals

LTBRZ3 Series can be turned ON or OFF by applying proper signals to the input pins named PNP enable and NPN enable.

Signal	Value	Safety range
PNP enable	Apply >4V to turn on the light	0V to 24V
NPN enable	Apply <1 to turn on the light (connect to GND)	0V to 24V

Table 9: PNP and NPN signals operating range.

Leave signals unconnected if not used

Do not try to force both PNP and NPN simultaneously.

The table below lists typical current consumption for both lines (PNP, NPN) and is valid for a single module.

Driving the enable with a 3.3 V signal is not recommended.

Signal	Voltage	Current consumption
PNP enable	5 V	3 mA
PNP enable	12 V	7.5 mA
PNP enable	24 V	15 mA
NPN enable	0 V	12 mA

Table 10: PNP and NPN signals power requirements for a single unit.

When multiple illuminators are connected in daisy-chain configuration, please consider the current consumptions listed below.

Signal	Voltage	PNP/NPN current consumption		
		2 units	3 units	4 units
PNP enable	5 V	6 mA	9 mA	12 mA
PNP enable	12 V	15 mA	22.5 mA	30 mA
PNP enable	24 V	30 mA	45 mA	60 mA
NPN enable	0 V	24 mA	36 mA	48 mA

Table 11: PNP and NPN signals power requirements for multiple units.

10.6 Timing performance of LTBRZ3-C

The Graphs below show typical turn-on behavior for LTBRZ3-C series when operating in non-continuous mode. The delay between the rising edge of the trigger signal (green) and the 50% of the light output signal (yellow) is ~344us.

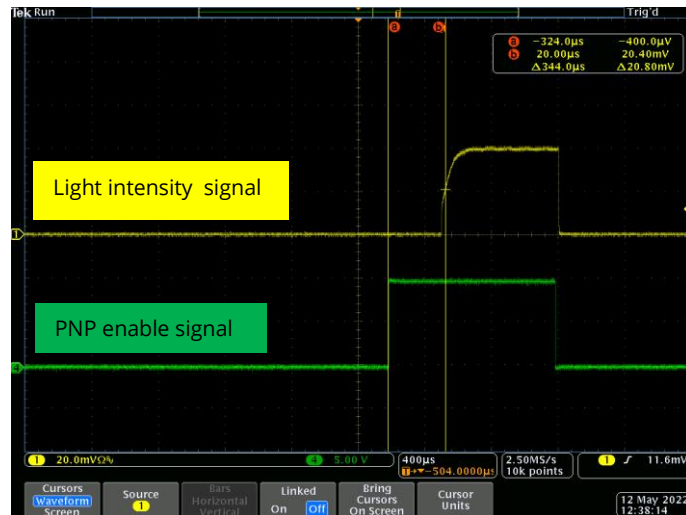

Figure 5: turn-on behavior for LTBRZ3-C series.

The Graph below shows typical turn-off behavior. The delay between the falling edge of the trigger signal (green) and the 50% of the light output signal (yellow) is ~22us.



Figure 6: turn-off behavior for LTBRZ3-C series.

Acquisitions are taken with a Ton time = 1ms and a Frequency = 10 Hz.

10.7 Timing performance of LTBRZ3-P

LTBRZ3-P is specifically designed for operating in non-continuous, pulsed mode. A fast high-current integrated driver is able to pulse LEDs with “micro-second” performance. The product is suitable for strobed/pulsed application when high-power and short exposures are mandatory. The Graph below shows a typical behavior. The green waveform is the trigger signal, while the blue is the light output signal.

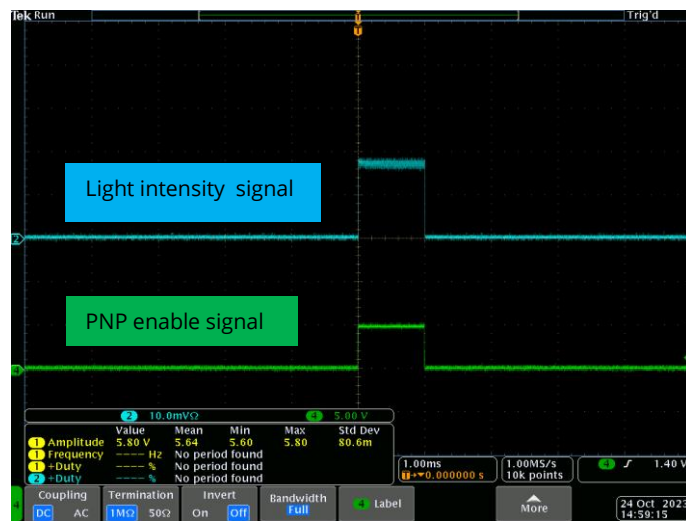

Figure 7: typical behavior for LTBRZ3-P series. Ton = 1 ms, Frequency = 100 Hz.

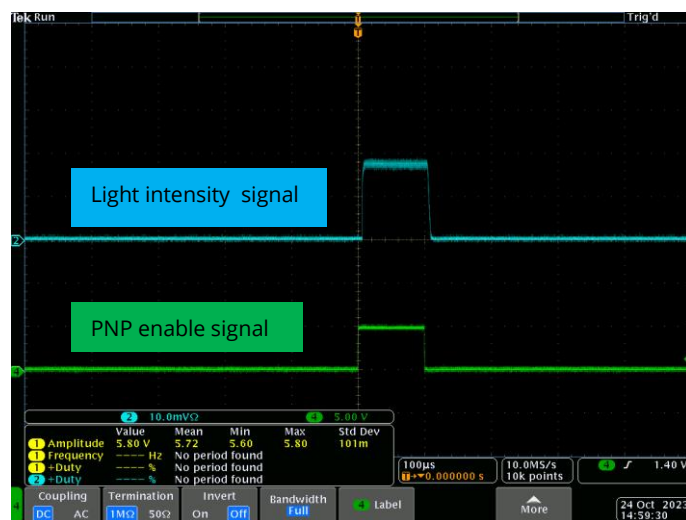

Figure 8: typical behavior for LTBRZ3-P series. Ton = 100 us, Frequency = 100 Hz.

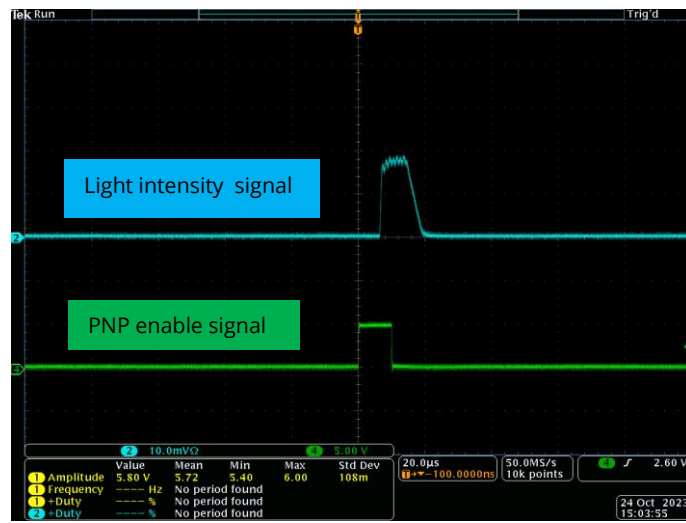

Figure 9: typical behavior for LTBRZ3-P series. Ton = 10 us, Frequency = 100 Hz.

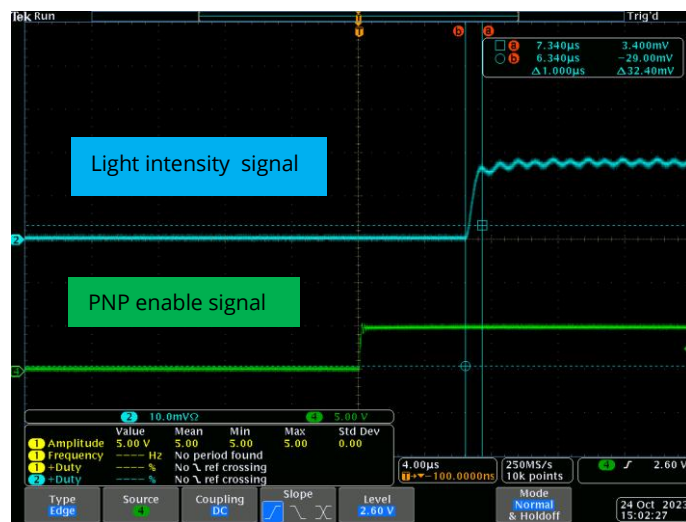

Figure 10: typical behavior for LTBRZ3-P series. Rise-time ~ 1us.

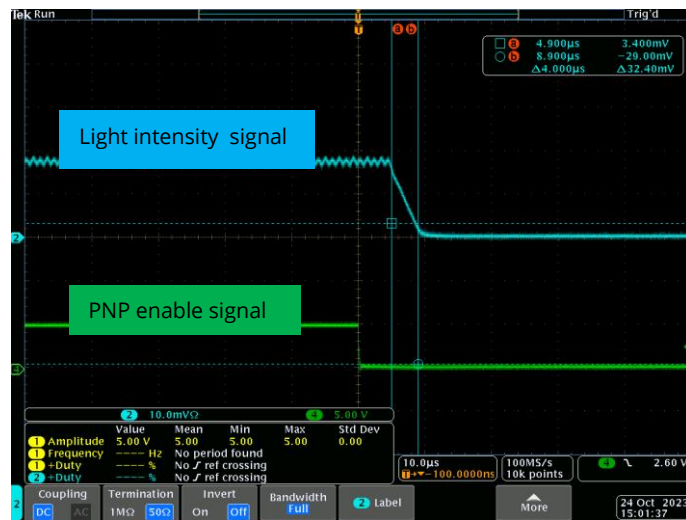

Figure 11: typical behavior for LTBRZ3-P series. Fall-time ~ 4µs.

Timing measurement are performed with a very fast detector and a large-bandwidth scope. Despite LTBRZ3-P can handle pulses of few microseconds, it is suggested to operate with a minimum Turn-on time of 8-10µs. The delay between the rising edge of the PNP signal and the rising edge of the light output is constant over time and typically <10µs. To keep this delay as short as possible, it is suggested to operate with dimming set to 100%. In order to preserve the electronics and the led board, the electronic has timing and thermal protections that limits both Ton and duty-cycle. When the protection circuit is engaged, pulses length is reduced and/or ignored and a visible flickering can appear. The table below lists the absolute maximum timing ratings admitted. It is suggested to not drive the modules with frequency higher that 1 kHz.

Maximum turn-on time	10 ms
Maximum duty-cycle	10%
Maximum operating frequency	1 kHz

10.8 Dimming

Dimming (brightness adjustment) of the light is provided in two ways:

- Dimming PIN on the connector (PIN #5).

Signal	Adjustment range	Maximum range
Analogue dimming	1V to 10V	0V to 24V

Table 12: Analogue dimming signal operating range.

- External potentiometer with 270° turning range. To adjust the potentiometer, use a flat blade screwdriver 0.4x2.5 [mm]. As default factory setting, the potentiometer is adjusted to “gain max”.

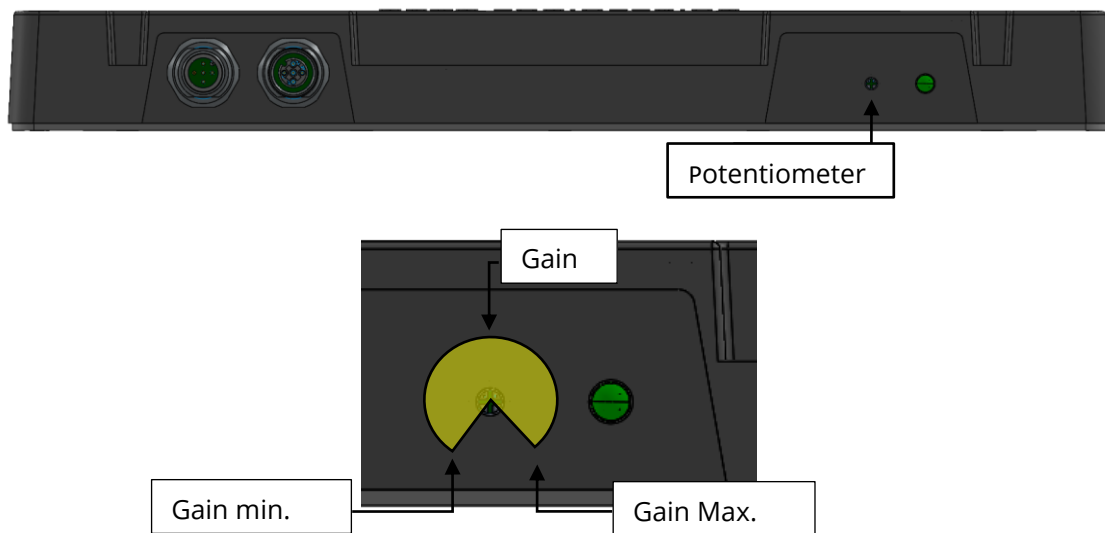

The table below shows the LED brightness as a function of Analogue dimming voltage in three different gain conditions (Gain 0, minimum and maximum). Please note what follows:

- With analogue dimming pin floating (unconnected), the potentiometer does not affect brightness adjustment, which is fixed to minimum level (30%);
- With analogue dimming voltage between 0V and 1V, the potentiometer does not affect brightness adjustment, which is fixed to minimum level (30%);
- With analogue dimming voltage between 1V and 10V, the potentiometer affects brightness adjustment according to the table below
- With analogue dimming voltage between 11V and 24V, the potentiometer affects brightness adjustment and allows a modulation between minimum level (30%) and maximum level (100%);

Dimming voltage [V]	LED brightness [%]		
	Gain min	Gain 0	Gain max
0	30%	30%	30%
1	30%	30%	46%
2	30%	39%	58%
3	30%	47%	70%
4	30%	54%	82%
5	30%	62%	94%
6	35%	70%	100%
7	39%	78%	100%
8	43%	86%	100%
9	47%	94%	100%
10	50%	100%	100%
11-24	30%	100%	100%

Table 13: LED brightness as a function of Dimming voltage and Gain.

The following graph shows the LED brightness response as a function of analogue signal for Gain = 0. The behavior is very linear between 1V and 10V.

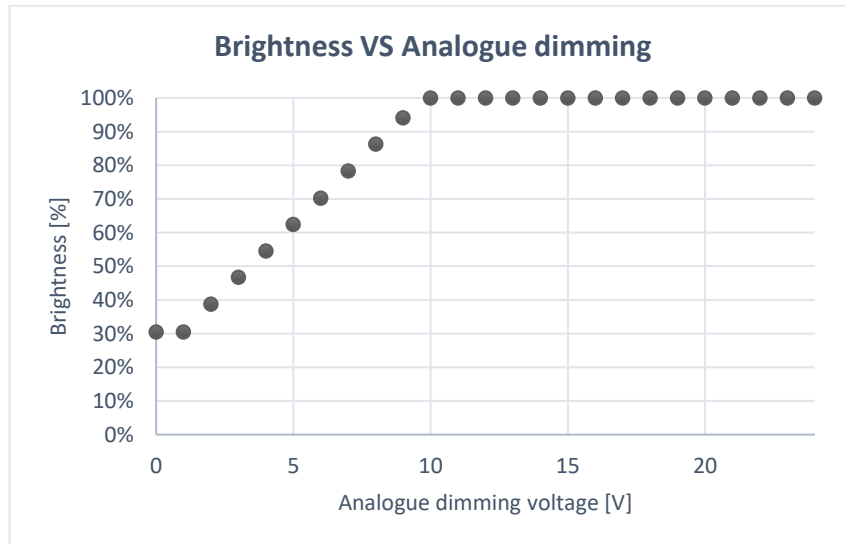

Figure 6: LED brightness VS analogue dimming voltage.

The table below lists typical current consumption for analogue dimming line and is valid for a single module.

Signal	Voltage	Current consumption
Analogue dimming	0 V	~ 0.000 mA
Analogue dimming	1 V	0.025 mA
Analogue dimming	5 V	0.125 mA
Analogue dimming	10 V	0.250 mA
Analogue dimming	24 V	< 2 mA

Table 14: Analogue dimming signal power requirements for a single unit.

When multiple illuminators are connected in daisy-chain operation, please consider the typical current consumptions listed below.

Signal	Voltage	Current consumption		
		2 units	3 units	4 units
Analogue dimming	24 V	4 mA	6 mA	8 mA

Table 15: Analogue dimming signal power requirements for multiple units.

10.9 Led indicator

LTBRZ3 Series is equipped with a RGB led indicator used to monitor both status and error conditions. The table below describes the led behavior.



Led status and color	Illuminator status
Solid green	Power supply is present, illuminator is OFF.
Solid blue	Power supply is present, illuminator is ON.
Alternately flashing	Error condition is detected.

Table 16: LED indicator signalling behavior.

When a fault is detected, four consecutive led flashes indicate the presence of one or more error conditions. The four flashes correspond to four possible error conditions, named E0, E1, E2 and E3. The flashes timing diagram is reported in the diagram below. Each flash lasts for 0.5" (500ms) and has a period of 1" (1s). The four flashes train is repeated every 6" (6s). The first flash corresponds to E0 (error0), the second to E1 (error1) and so on. If the E0 flash is green, there is no error, if red, error is present.

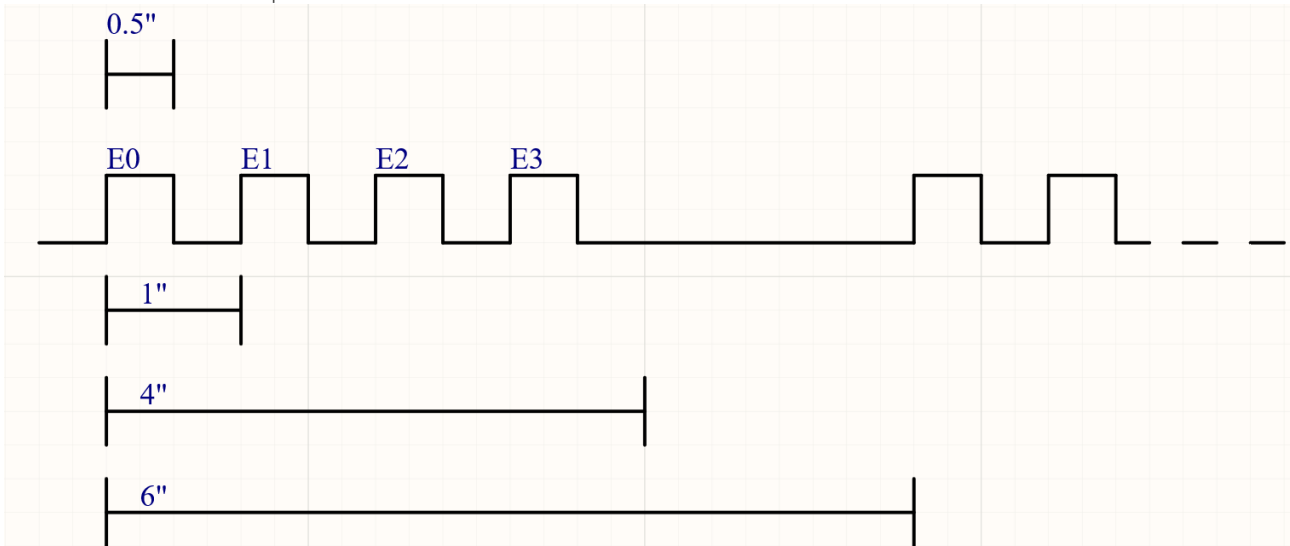

Example 1:

- 1st flash is green
- 2nd flash is red
- 3rd flash is green
- 4th flash is green

This means that only error1 (E1) has been detected.

Example 2:

- 1st flash is red
- 2nd flash is red
- 3rd flash is green
- 4th flash is green

This means that two errors have been detected, error0 (E0) and error1 (E1). The following table lists how errors are coded.

Error code	Description
E0	Driver overtemperature detected
E1	Led board overtemperature detected
E2	Supply voltage error (undervoltage shutdown occurred)
E3	Power supply failure detected

Table 17: Error code explanation.

When at least one error is present, the LED is instantly switched OFF and the illuminator enters the error signaling routine, that continues until error(s) persist. The electronics automatically re-starts normally operation in case of error resetting.

Particular attention must be paid to error code E1. This means that the LED board on the back of the illuminator has reached a too high temperature. This can be caused by:

- Environmental temperature > 40°C
- Ventilation not present
- Temperature of the attaching mechanics too high

10.10 Optical layout and performances

LTBRZ3 Series is composed by 12 high-power LED sources, disposed as a linear array. Illumination area has dimensions 295 x 25 mm. Led array is covered by a plastic protection window.



The series can be equipped with different options, detailed below.

10.10.1 Led color options

LTBRZ3 series offer a selection of different led colors ranging from visible to infrared. Five colors are available as default, others are upon request.

Option	Color	Peak wavelength	FWHM	Color temperature
-B	Blue	470 nm	25	-
-G	Green	530 nm	35	-
-R	Red	630 nm	20	-
-IR	Infrared	860 nm	40	-
-W	White	-	-	6500 K

Table 18: LED color options.

The following graphs show the typical emission spectra for the default color series. Reported data are measured.

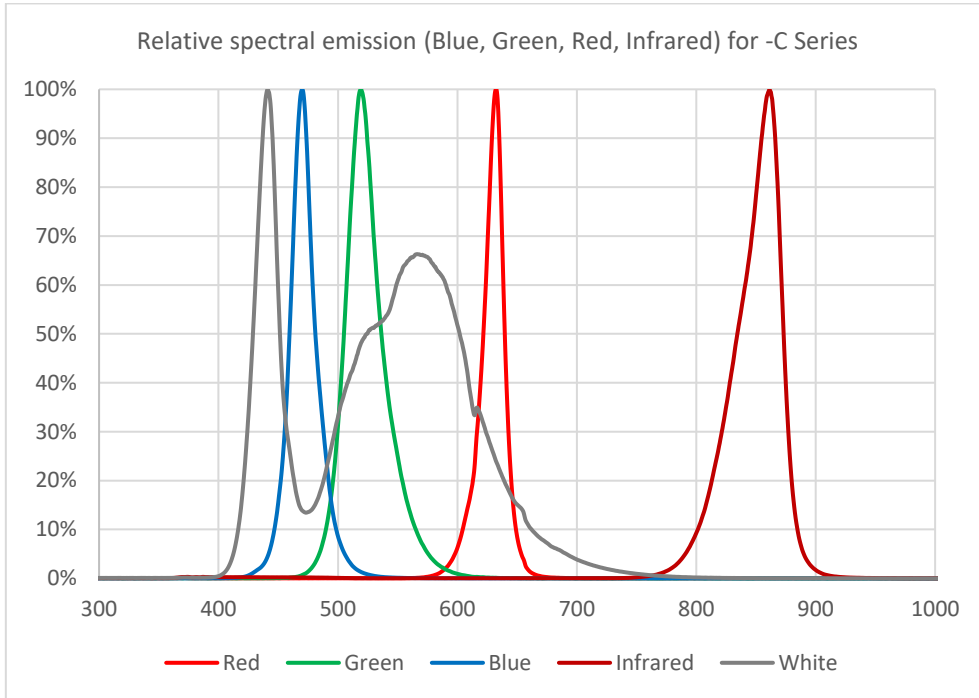

Figure 7: Spectrum of LTBRZ3-C Series.

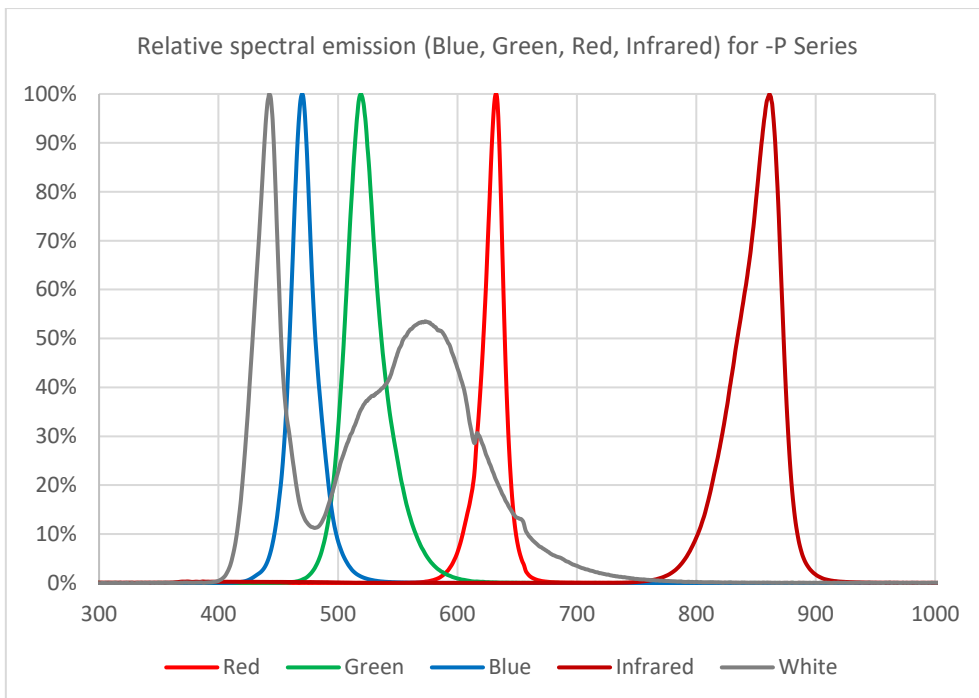

Figure 8: Spectrum of LTBRZ3-P Series.

10.10.2 Lens options

The table below list the 6 lens options available for LTBRZ3 series. Others are upon request.

Option	Description
-10	Each led emits a circular beam with aperture of ~10°
-20	Each led emits a circular beam with aperture of ~20°
-30	Each led emits a circular beam with aperture of ~30°
-50	Each led emits a circular beam with aperture of ~50°
-EL	Each led emits an elliptical beam with horizontal aperture of ~35° and vertical aperture of ~15°
-BL	LEDs emits a uniform pattern suitable for backlight applications

Table 19: Lens options.

- **Option [-10]:**

this configuration is provided with 12 lenses mounted on Leds. Each lens emits a beam with a circular aperture of ~10°. A weak diffusing window is placed in front of lenses. The purpose of the diffuser is to reduce glare and homogenize the beam. This configuration projects a narrow beam of light ideal for long working distances and applications that require pseudo collimated light. The pictures below show the light pattern at three different working distances.

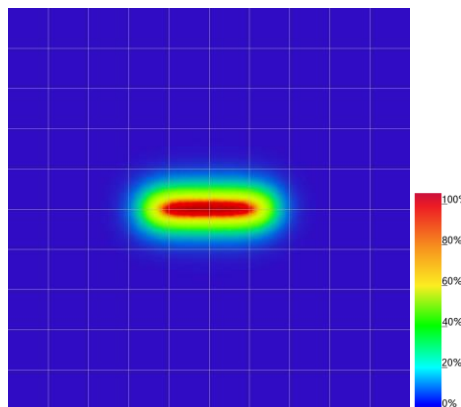

Figure 9: estimated intensity pattern for option (-10), working distance: 300mm, grid spacing: 50mm, color: white.

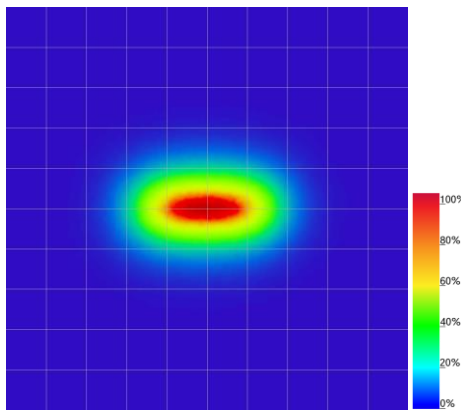

Figure 11: estim estimated intensity pattern for option (-10), working distance: 500mm, grid spacing: 50mm, color: white.

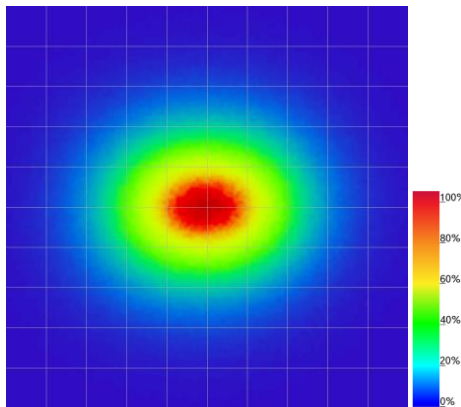

Figure 10: estimated intensity pattern for option (-10), working distance: 1000mm, grid spacing: 50mm, color: white.

- **Option [-20]:**

this configuration is provided with 12 lenses mounted directly on Leds. Each lens emits a circular beam with aperture of $\sim 20^\circ$. A weakly diffusing window is placed in front of lenses. The purpose of the diffuser is to reduce glare and homogenize the beam. This configuration projects a medium beam of light. The pictures below show the light pattern at three different working distances.

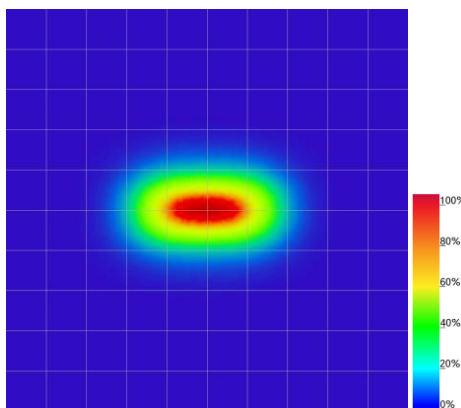

Figure 11: estimated intensity pattern for option (-20), working distance: 300mm, grid spacing: 50mm, color: white.

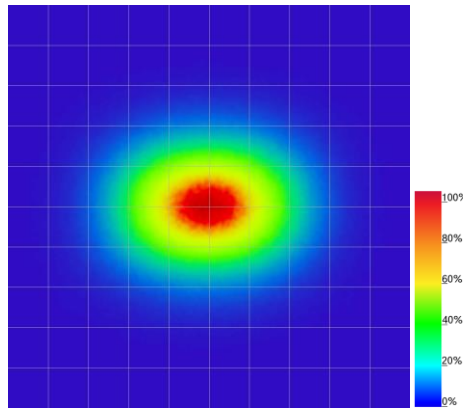

Figure 12: estimated intensity pattern for option (-20), working distance: 500mm, grid spacing: 50mm, color: white.

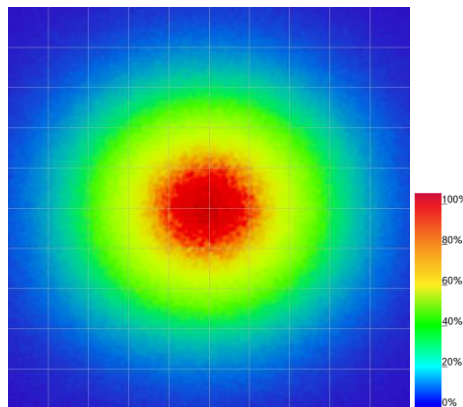

Figure 13: estimated intensity pattern for option (-20), working distance: 1000mm, grid spacing: 50mm, color: white.

- **Option [-30]:**

this configuration is provided with 12 lenses mounted directly on Leds. Each lens emits a circular beam with aperture of $\sim 30^\circ$. A weakly diffusing window is placed in front of lenses. The purpose of the diffuser is to reduce glare and homogenize the beam. This configuration projects a wide beam of light. The pictures below show the light pattern at three different working distances.

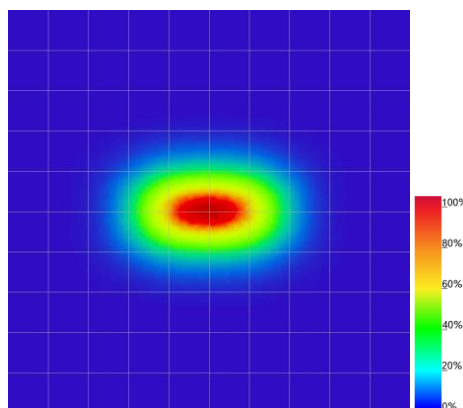

Figure 14: estimated intensity pattern for option (-30), working distance: 300mm, grid spacing: 50mm, color: white.

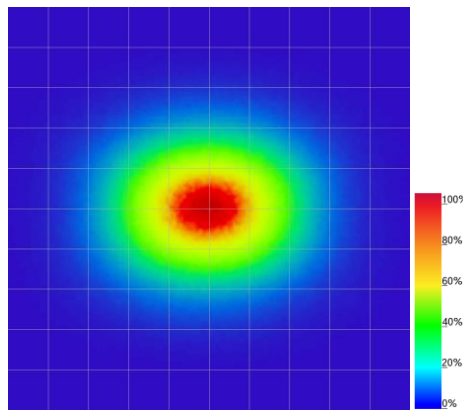

Figure 15: estimated intensity pattern for option (-30), working distance: 500mm, grid spacing: 50mm, color: white.

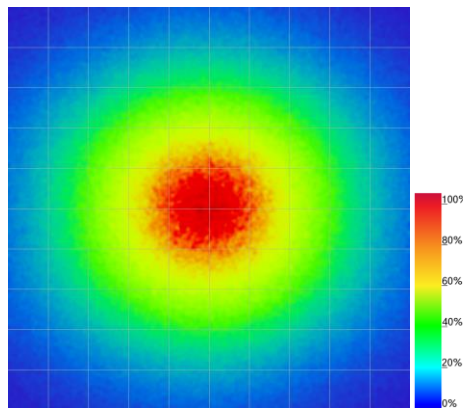

Figure 16: estimated intensity pattern for option (-30), working distance: 1000mm, grid spacing: 50mm, color: white.

- **Option [-50]:**

this configuration is provided with 12 lenses mounted directly on Leds. Each lens emits a circular beam with aperture of $\sim 50^\circ$. A weakly diffusing window is placed in front of lenses. The purpose of the diffuser is to reduce glare and homogenize the beam. This configuration projects an extra-wide beam of light ideal to cover large illumination area in short distance applications. The pictures below show the light pattern at three different working distances.

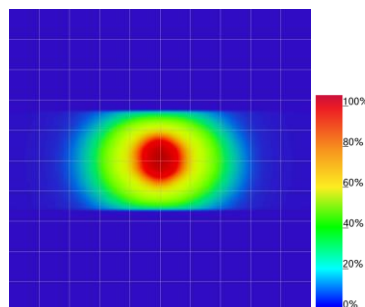

Figure 17: estimated intensity pattern for option (-50), working distance: 300mm, grid spacing: 50mm, color: white.

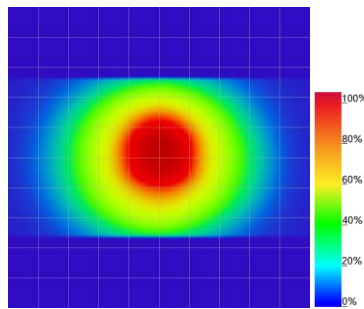

Figure 18: estimated intensity pattern for option (-50), working distance: 500mm, grid spacing: 50mm, color: white.

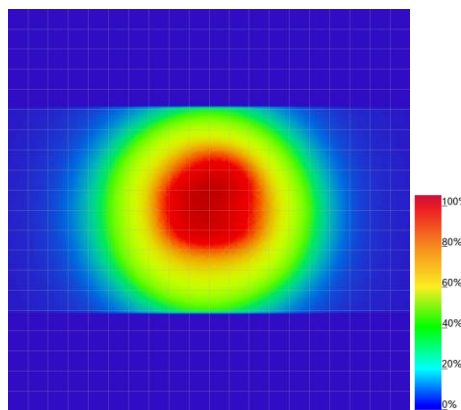

Figure 19: estimated intensity pattern for option (-50), working distance: 500mm, grid spacing: 50mm, color: white.

- **Option [-EL]:**

this configuration is provided with 12 lenses mounted directly on Leds. Each lens emits an elliptical beam with horizontal aperture of $\sim 35^\circ$ and vertical aperture of $\sim 15^\circ$. A weakly diffusing window is placed in front of lenses. The purpose of the diffuser is to reduce glare and homogenize the beam. This configuration projects a beam that is wide along the X axis and narrow along the Y axis. It is ideal for applications that require an asymmetrical beam.

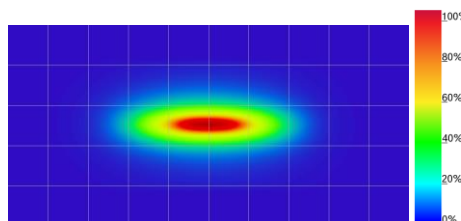

Figure 20: estimated intensity pattern for option (-EL), working distance: 300mm, grid spacing: 50mm, color: white.

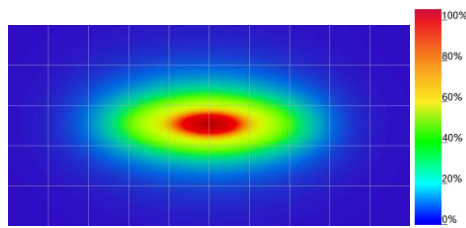

Figure 21: estimated intensity pattern for option (-EL), working distance: 300mm, grid spacing: 50mm, color: white.

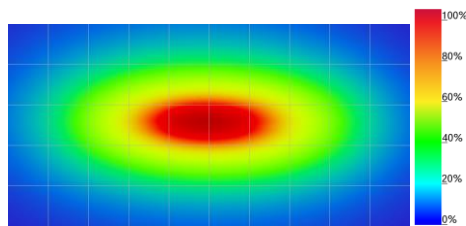

Figure 22: estimated intensity pattern for option (-EL), working distance: 300mm, grid spacing: 50mm, color: white.

- **Option [-BL]:**

this configuration provides a diffused light pattern over all the active area. This pattern is suitable for backlight applications.



Figure 23: light pattern at the diffuser surface, color: white.

A test report with measured performance will be provided only for this configuration.

Important note: please consider the data provided here as based on either laboratory measurements or computer simulations, and that actual results in different setups, conditions and environments may vary. The quality of light and its effect on the sample must be evaluated by the customer.

10.10.3 Polarizer options

LTBRZ3 series can be equipped with a polarizer film mounted on top of the diffusor. Generally, polarizing films are used in a wide variety of applications. A linear polarizer is a good solution in applications that require glare reduction due to direct reflected lights. Machine vision systems greatly benefit from the use of linear polarizers. 3 possible options are available and are listed in the table below. The polarizers are linear.

Option	Description
-PH	The polarizing axis of the film is parallel to the width of the illuminator
-PV	The polarizing axis of the film is parallel to the height of the illuminator
Empty	No polarizers mounted

Figure 24: Polarizing option.

Please note what follows: if using a single LTBRZ3 module, in some applications the polarizing direction is not critical. Consequently both -PH and -PV options can work with good result. This is not true when multiple illuminators are used together, for example with 4 LTBRZ3 forming a square pattern. In this case it is important to respect the linear direction of the polarization.

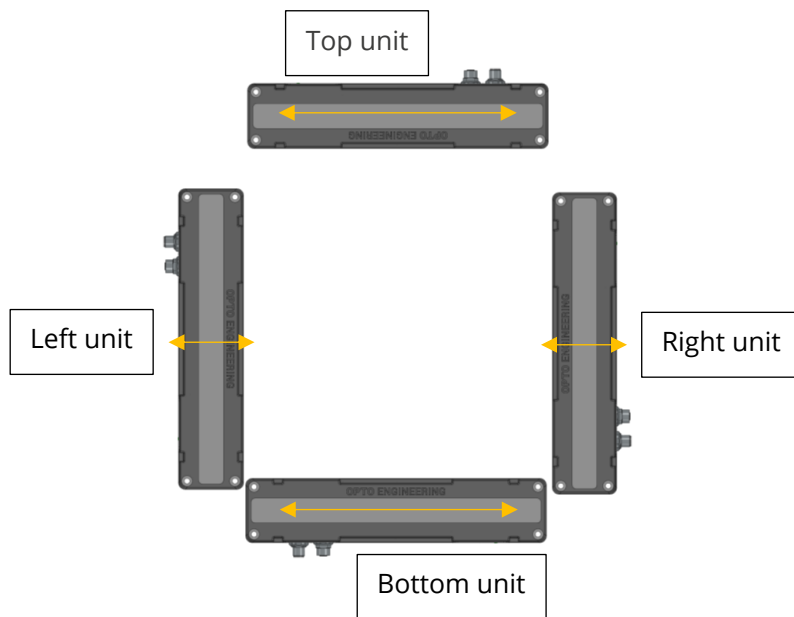

The case depicted requires (in normal applications) the usage of 2 different polarizations, depending on the position of the illuminator. The table below shows the suggested options.

Unit	Suggested polarization option	Alternative possible option
Top	-PH	-PV
Bottom	-PH	-PV
Left	-PV	-PH

Right	-PV	-PH
-------	-----	-----

Please consider this example as a target for some applications, considering it as a general guideline for multiple illuminator displacement.

If options -PH or -PV are installed, the appearance of the diffuser will be darker if compared to the version without polarizer.

For Infrared versions, polarizer options (-PH and -PV) are not available.

10.10.4 Illuminance/irradiance data

The plot below reports the illuminance/irradiance of various configurations measured at various working distances. Working distance is defined as the distance between the front of the mechanics and the measurement plane. All the measures are taken at the center of the active area.

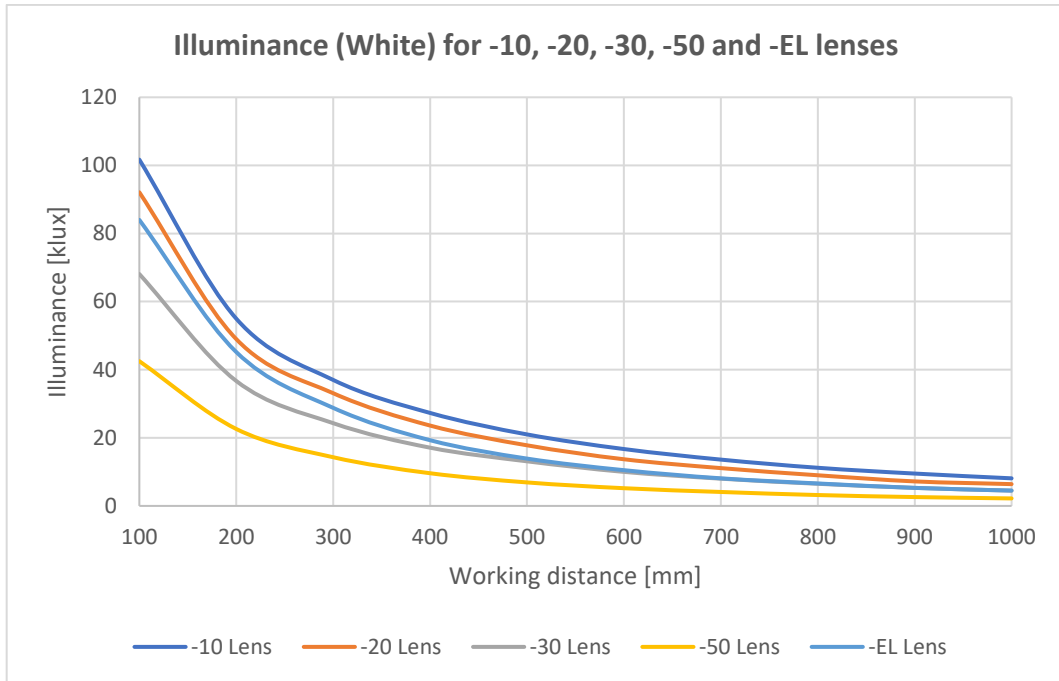

Figure 24: Illuminance of LTBRZ3-C Series, same colour (White), different lenses.

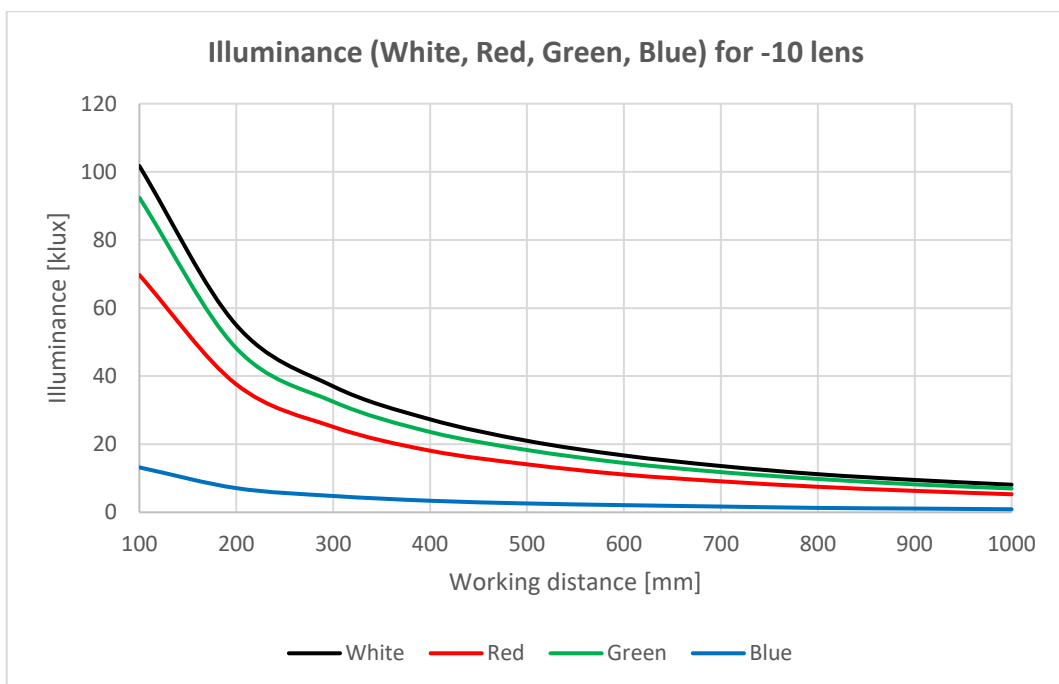

Figure 25: Illuminance of LTBRZ3-C Series, same lens (-10), different colours.

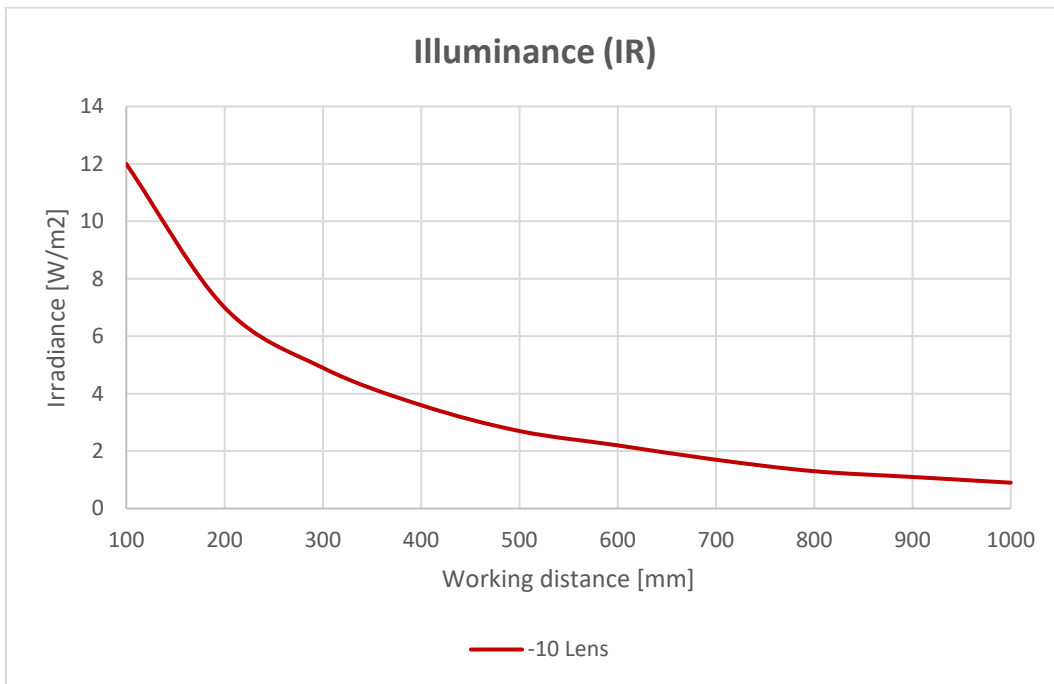

Figure 26: Irradiance of LTBRZ3-C Series, infrared with "-10" lens.

For LTBRZ3-C-W-BL model: Illuminance value is ~44 klux measured in front of the diffuser in central position (working distance: 0 mm).

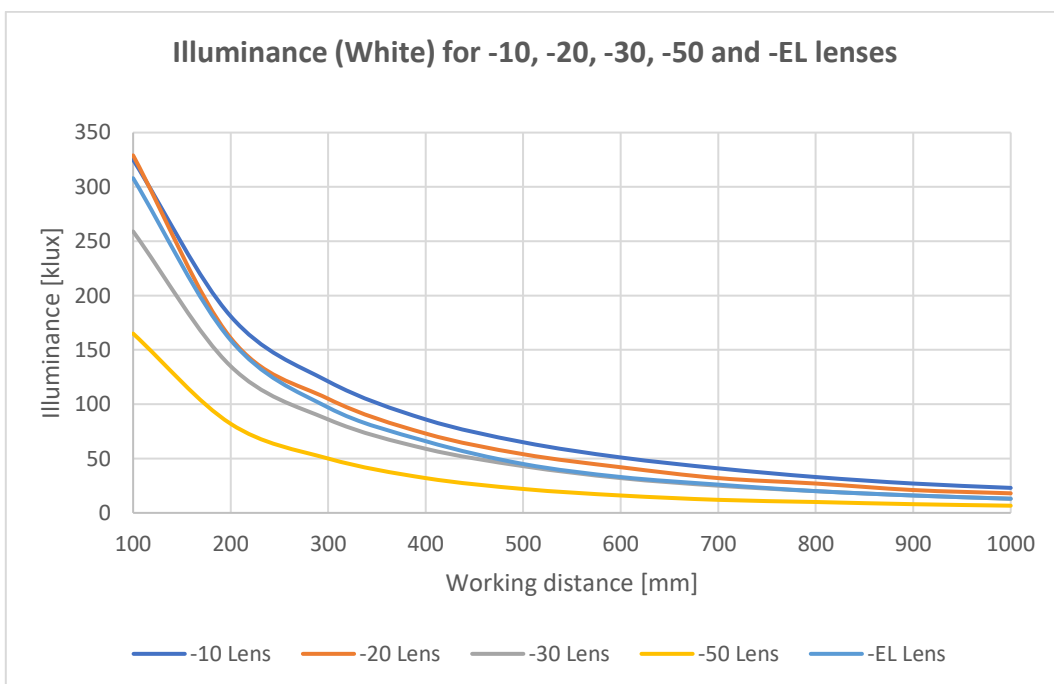

Figure 27: Illuminance of LTBRZ3-P Series, same colour (White), different lenses.

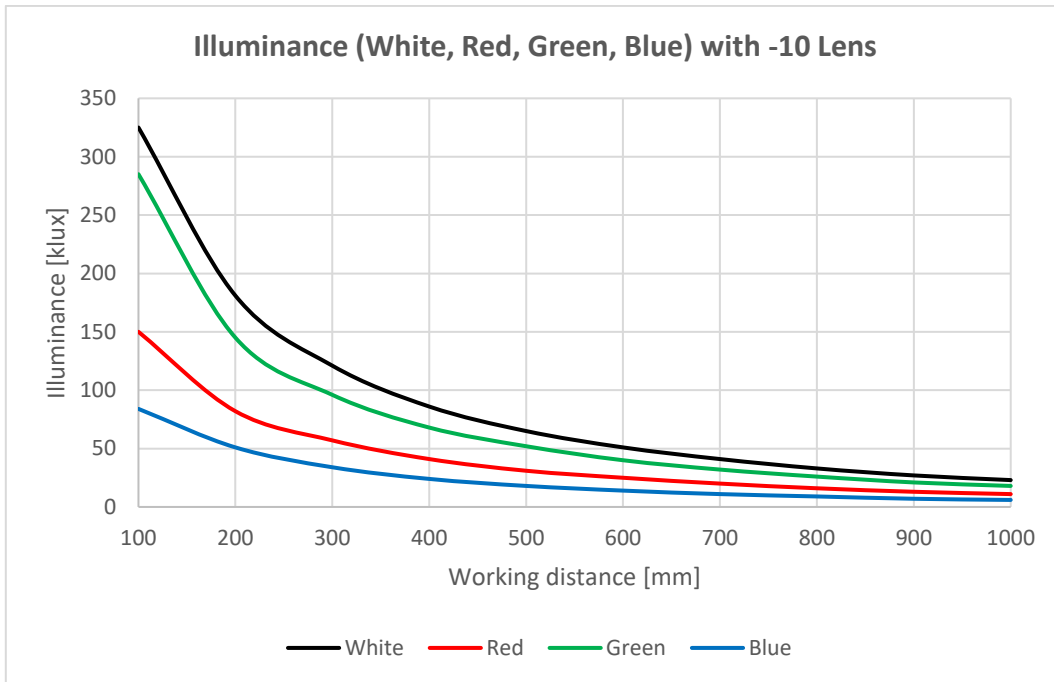

Figure 28: Illuminance of LTBRZ3-P Series, same lens (-10), different colours.

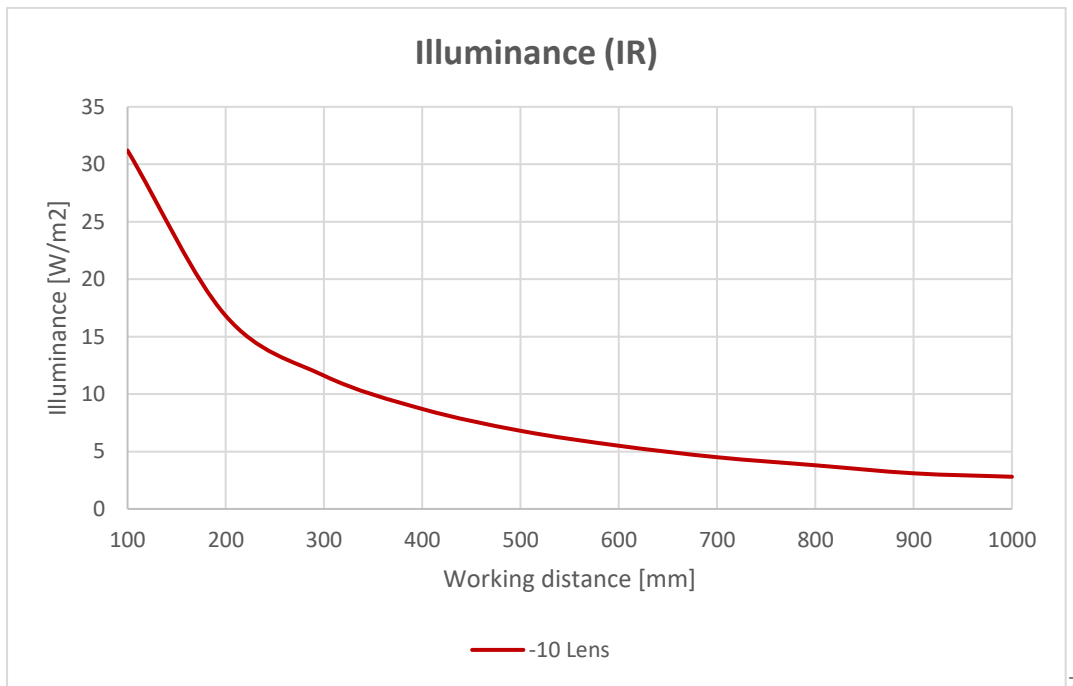

Figure 29: Irradiance of LTBRZ3-P Series, infrared with "-10" lens.

For LTBRZ3-P-W-BL model: Illuminance value is ~170 klux measured in front of the diffuser in central position (working distance: 0 mm).

10.10.5 Led current ripple of LTBRZ3-C

LTBRZ3-C integrates an ultra-low ripple led driving electronic. This means that the led average current is practically constant over time. Output ripple is around ~2%, very low if compared to traditional illuminators on the market, which normally exhibit tens of %. This allows a high constancy light output. Picture below shows a 10ms pulse with extremely flat and constant performance.

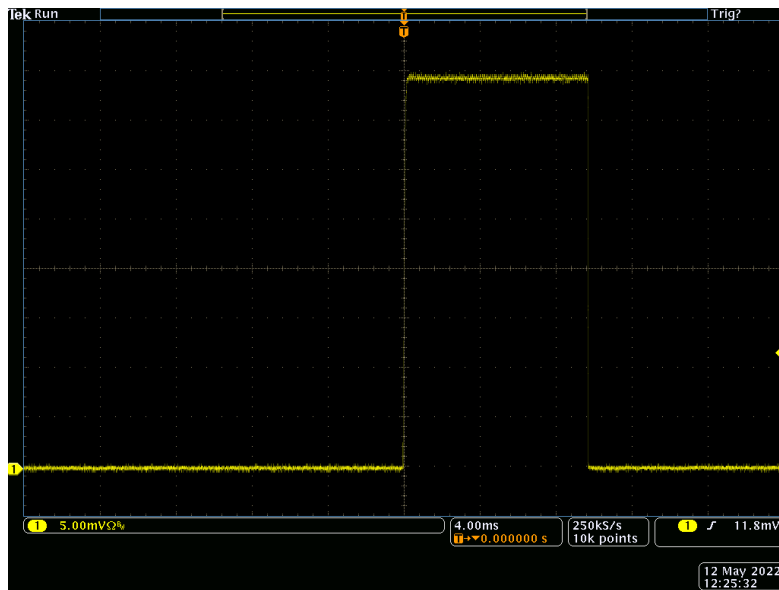

Figure 30: LED output intensity VS time, pulse width: 10ms.

11. Dimensions

Dimensions: 306.25 (L) x 33.50 (W) x 65.25 (H) [mm]

Weight: ~400g

Fixing: N°4 THRU holes for M5 screws

Note: during the device set up, be sure that the product is not connected to the power supply. Please use M5 screws, inserting them into the 4 holes at the corners of the device. We recommend to use a thread-locker to avoid any risk of loosening. Suggested screw tightening torque is 1 – 2 Nm.

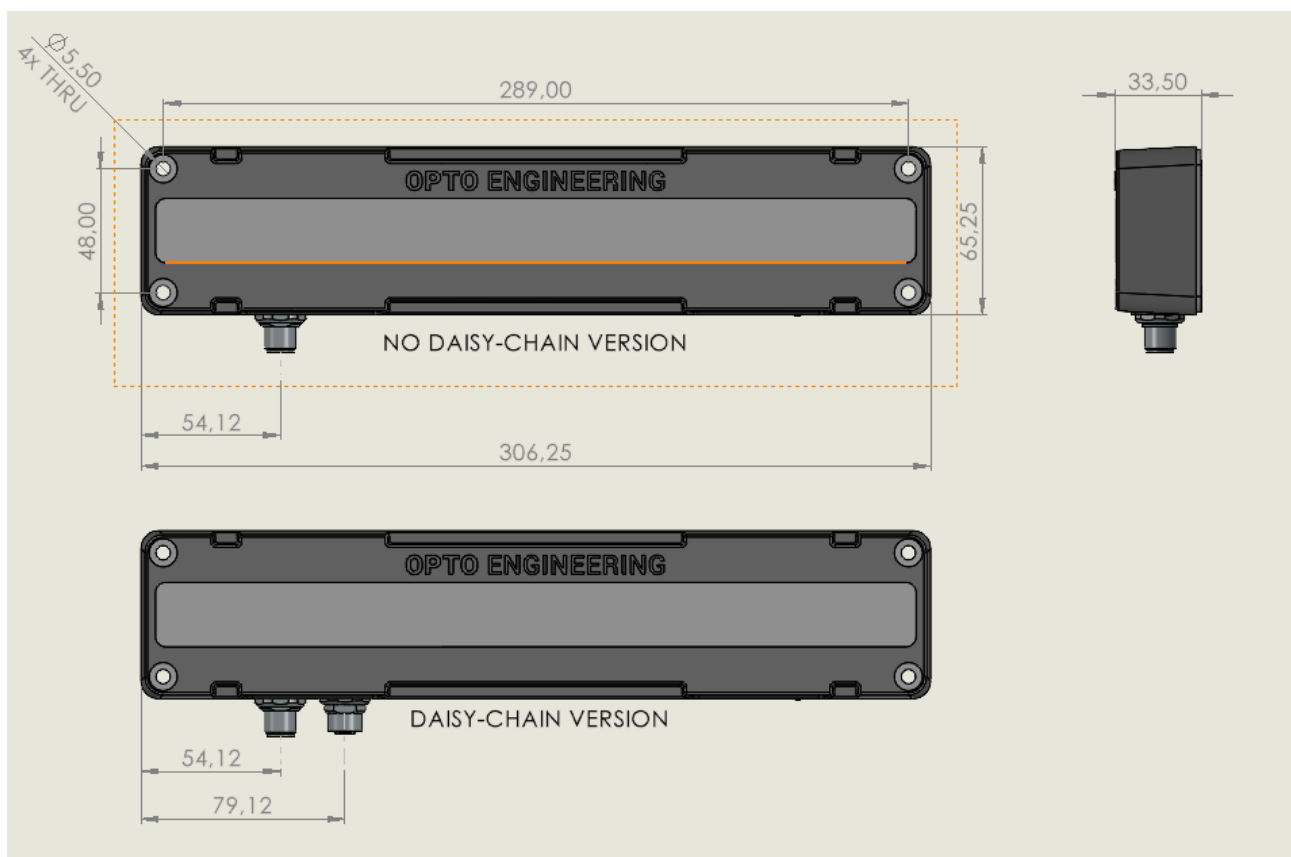

12. Electromagnetic compatibility

LTBRZ3 Series conforms to EN 61326-1:2013 class A requirements for electromagnetic interference (EMI) suppression.

13. Revision hystory

Version	Date	Action
1.00	23/05/2022	First release
1.01	10/06/2022	Dimming paragraph has been updated
1.02	10/04/2024	LTBRZ3-P Series has been added

EUROPE

Opto Engineering

Europe Headquarters

Circonvallazione Sud, 15

46100 Mantova, IT

phone: +39 0376 699111

eu@opto-e.com

Opto Engineering

Germany

Marktplatz 3,

82031 Grünwald, DE

phone: +49 (0)89 693 9671-0

de@opto-e.com

Opto Engineering

Russia

official partner

ViTec Co., Ltd, Fontanka emb., 170

Saint-Petersburg, 198035, RU

phone: +7 812 5754591

ru@opto-e.com

UNITED STATES

Opto Engineering

USA

11321 Richmond Ave

Suite M-105, Houston, TX 77082, USA

phone: +1 832 2129391

us@opto-e.com



ASIA

Opto Engineering

China

Room 1903-1904, No.885, Renmin RD

Huangpu District 200010

Shanghai, CN

phone: +86 21 61356711

cn@opto-e.com

Opto Engineering

Japan

official partner

Optart Corporation

4-54-5 Kameido Koto-ku

Tokyo, 136-0071, JP

phone: +81 3 56285116

jp@opto-e.com

Opto Engineering

Korea

official partner

Far Island Corporation Ltd.

Seoil Building #703, 353 Sapyeong-daero,

Seocho-gu, Seoul 06542, KR

phone: +82 70 767 86098

phone: +82 10 396 86098

kr@opto-e.com

Opto Engineering

Thailand

official partner

Logical Technology co., Ltd

Nanthawan Srinakarin Village

233/613 No.5, Bang Muang Subdistrict,

Muang Samutprakan District,

Samutprakan 10270, TH

phone: +66 (0)21217028

th@opto-e.com